



# DN370

## OPERATORS MANUAL

**KLARK TEKNIK DN370**

Klark Teknik Group,  
Klark Teknik Building,  
Walter Nash Road,  
Kidderminster,  
Worcestershire,  
DY11 7HJ  
England

Tel: +44 (0) 1562 741515

Fax: +44 (0) 1562 745371

Email: [sales@ktgplc.com](mailto:sales@ktgplc.com)

Website: [www.klarkteknik.com](http://www.klarkteknik.com)



**KLARK TEKNIK**  
SIGNAL PROCESSING BY DEFINITION



[www.liveline.be](http://www.liveline.be)  
**IMPORTANT SAFETY INSTRUCTIONS**



These symbols are internationally accepted symbols that warn of potential hazards with electrical products.

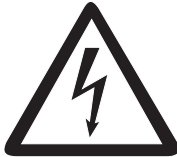

The lightning flash with arrowhead symbol, within an equilateral triangle is intended to alert the user to the presence of uninsulated "dangerous voltage" within the product's enclosure that may be of sufficient magnitude to constitute a risk of electric shock to persons.



The exclamation point within an equilateral triangle is intended to alert the user to the presence of important operating and maintenance (servicing) instructions in the literature accompanying the appliance.

1. Read these instructions.
2. Keep these instructions.
3. Heed all warnings.
4. Follow all instructions.
5. Do not use this apparatus near water.
6. Clean only with a dry cloth.
7. Do not block any of the ventilation openings. Install in accordance with the manufacturers instructions.
8. Do not install near any heat sources such as radiators, heat registers, stoves, or other apparatus (including amplifiers) that produce heat.
9. Do not defeat the safety purpose of the polarized or grounding-type plug. A polarized plug has two blades with one wider than the other. A grounding type plug has two blades and a third grounding prong. The wide blade or the third prong are provided for your safety. If the provided plug does not fit into your outlet, consult an electrician for replacement of the obsolete outlet.
10. Protect the power cord from being walked on or pinched particularly at plugs, convenience receptacles, and the point where they exit from the apparatus.
11. Only use attachments / accessories specified by the manufacturer.
12. Unplug this apparatus during lightning storms or when unused for long periods of time.
13. Refer all servicing to qualified personnel. Servicing is required when the apparatus is damaged in any way, such as power-supply cord or plug is damaged, liquid has been spilled or objects have fallen into the apparatus, the apparatus has been exposed to rain or moisture, does not operate normally, or has been dropped.





Klark Teknik Group (UK) Plc, Klark Teknik Building, Walter Nash Road, Kidderminster, Worcs. DY11 7HJ, England  
 Tel: +44 1562 741515 Fax: +44 1562 745371  
 www.midasconsoles.com www.klarkteknik.com

## DECLARATION OF CONFORMITY

We, **Klark Teknik Group (UK) Plc**

of, Klark Teknik Building, Walter Nash Road, Kidderminster, Worcestershire, DY11 7HJ.

Declare that a sample of the following product:-

Product Type Number	Product Description	Nominal Voltage (s)	Current	Freq
DN370	Analogue Graphic Equaliser	115V AC 230V AC	240mA 120mA	50/60Hz

to which this declaration refers, is in conformity with the following directives and/or standards:-

89/336/EEC Electromagnetic Compatibility Directive amended by 92/31/EEC & 93/68/EEC 73/23/EEC, Low Voltage Directive, amended by 93/68/EEC	
Generic Standard Using EN55103 Limits and Methods	EN50081/1
Class B Conducted Emissions Pavi	EN55103
Class B Radiated Emissions Pavi	EN55103
Fast Transient Bursts at 2kV	EN61000-4-4
Static Discharge at 4kV	EN61000-4-2
Electrical Stress Test	EN60204
Electrical Safety	EN60065:2002

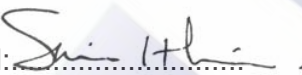
Signed:   
 Name: Simon Harrison

Date: 31<sup>st</sup> March 2004

Authority: Research and Development Director, Klark Teknik Group (UK) Plc

### Attention!

Where applicable, the attention of the specifier, purchaser, installer or user is drawn to special limitations of use which must be observed when these products are taken into service to maintain compliance with the above directives. Details of these special measures and limitations to use are available on request and are available in product manuals.





**Thank You** for using a Klark Teknik DN370 Graphic Equaliser. The DN370 has been developed to meet the needs of demanding live, recording and broadcast sound engineers and meets the quality in build and performance that you would expect from Klark Teknik.

The DN370 is a dual thirty(30) band third octave graphic equaliser with long throw forty-five millimetre (45mm) faders, two (2) high and low pass filters per channel and two (2) notch filters per channel. The DN370 is the latest addition to the world renowned DN300 series of Graphic Equalisers that are in use around the world today and represents the next generation of graphic equaliser technology.

All backed up, of course, by the standard Klark Teknik three year warranty.

Please take the time to complete and return the registration card and, to obtain the best results with a minimum of effort, also read this operators manual.

Finally, enjoy your Klark Teknik DN370!

## Contents

<b>ATTENTION</b>	Page 2
<b>Quick Reference</b>	
Front Panel	Page 3
Rear Panel	Page 4
<b>Features</b>	
Front Panel	Page 5
Rear Panel	Page 7
<b>System Example</b>	Page 9
<b>Using the DN370</b>	Page 10
Equalising a System	Page 11
The effect of equalisation	Page 12
<b>Functional Block Diagram</b>	Page 13
<b>The DN370 Proportional-Q response</b>	Page 14
<b>DN370 Applications</b>	Page 17
<b>Technical Specification</b>	Page 21
<b>Frequency Range Chart</b>	Page 22
<b>Crib Sheet</b>	Page 23



The following special limitations must be observed in order to maintain safety and electromagnetic compatibility performance.

**Power Connection**

The DN370 Graphic Equaliser should only be operated with the power supply connected to ground via the ground in the mains connector.

**Audio Connections**

The DN370 should only be operated with high quality twisted-pair audio cables. XLR connector shells should be of metal construction so that they provide a screen when connected to the console and should have pin one (1) connected to the cable screen.

**Electric Fields**

If the DN370 is operated in an electromagnetic field that is amplitude modulated by an audio frequency signal, the signal to noise ratio may be degraded. Degradation of up to 60dB may be experienced under extreme conditions (3V/m, 90% modulation).

**INSTALLATION**

**Position**

The DN370 should be mounted in a nineteen inch (19") rack of suitable construction for it's intended purpose. Four (4) rack mount holes are provided through the front panel to support fully, the weight of the unit in the rack. Position of the unit will depend upon how it is to be used however:-

- Avoid placing the unit such that the faders may be accidentally knocked or snapped off
- Avoid placing the unit such that the front mounted power switch may be accidentally knocked

Also try to avoid placing the unit directly near or on any power distribution units or power amplifiers.

**Power**

The internal power supply is a switch mode type which automatically senses the incoming mains voltage and will work where the nominal voltage is in the range 100-240 VAC. A single fused IEC mains inlet is provided on the rear panel and the correct lead for connection in the area to which the unit was shipped is provided in the box.

**Connections**

To ensure the correct and reliable operation of your DN370 Graphic Equaliser, only high quality balanced screened twisted pair audio cable should be used.



**Female XLR**  
 Pin 1 - Screen/Ground  
 Pin 2 - Hot Signal  
 Pin 3 - Cold Signal



**Male XLR**  
 Pin 1 - Screen/Ground  
 Pin 2 - Hot Signal  
 Pin 3 - Cold Signal

Note: XLR Sockets are viewed from the front face.



**Phoenix Type Connector**  
 Pin 1 - Channel IN Screen/Ground  
 Pin 2 - Channel IN Hot Signal  
 Pin 3 - Channel IN Cold Signal  
 Pin 4 - Channel OUT Screen/Ground  
 Pin 5 - Channel OUT Hot Signal  
 Pin 6 - Channel OUT Cold Signal

Note: Pin assignments as viewed from the socket. Phoenix connector is wired in parallel with the corresponding XLR.

**After Unpacking**

After unpacking your DN370, please retain the original packing in the event that you should need to transport or ship the unit. Please inspect the unit carefully for any signs of damage that may have occurred in transit and notify the courier immediately if you feel that any damage has occurred.





The Klark Teknik DN370 is a dual thirty (30) band, third octave graphic equaliser.

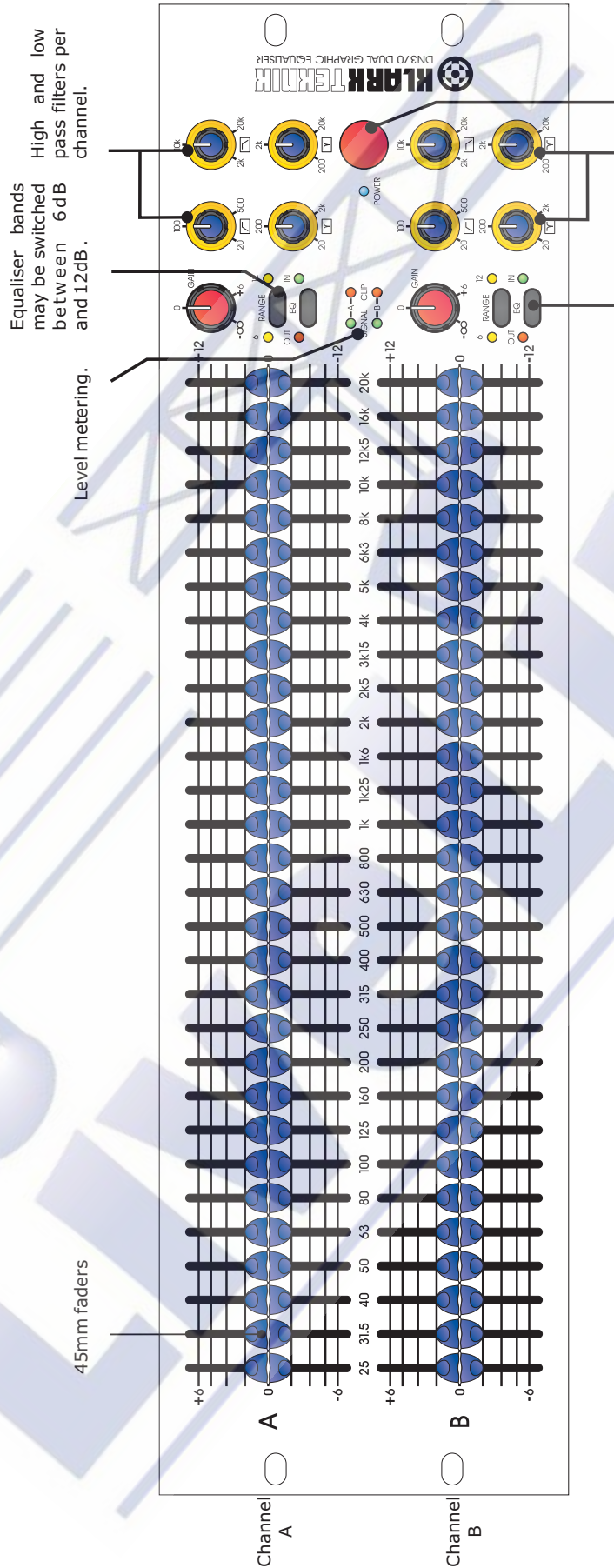

Equaliser bands may be switched between 6dB and 12dB. High and low pass filters per channel.

Level metering.

45mm faders

Equaliser in/out switch to bypass effect of the equaliser

Notch filters per channel.

Power switch and power indicator.

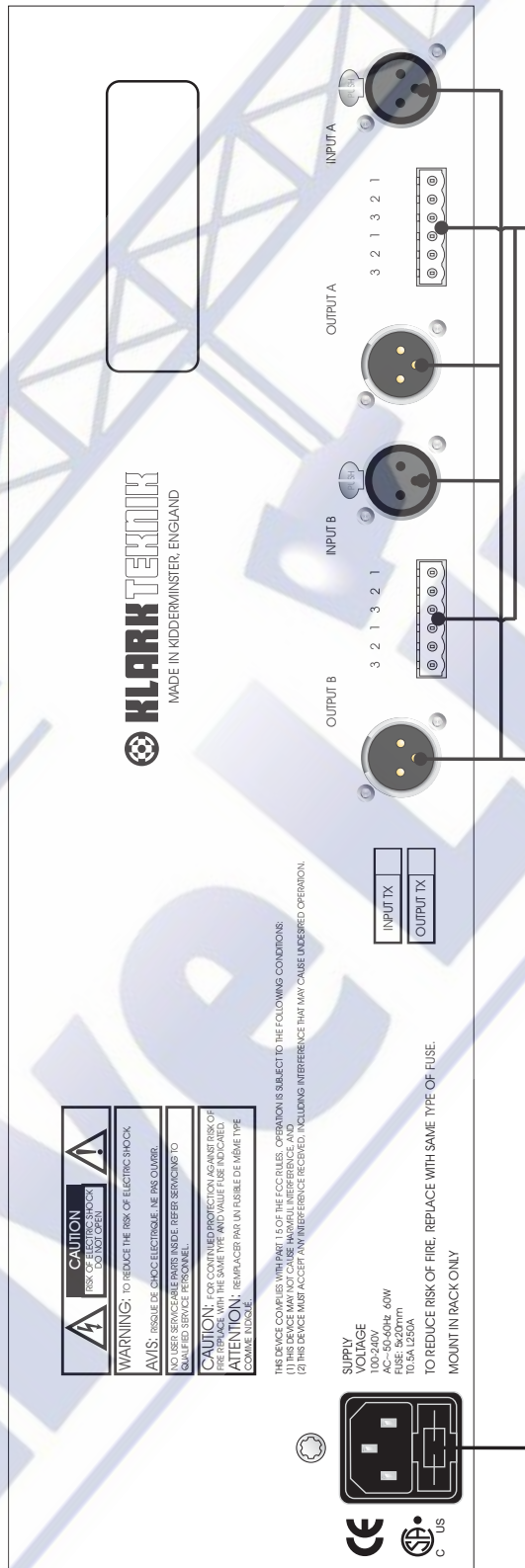

Fused IEC type connector



### Front Panel Features

The Klark Teknik DN370 is a dual thirty (30) band, third octave graphic equaliser. The range of the equaliser bands may be switched between 6dB and 12dB (individually for each channel). In addition to the graphic equaliser itself; high and low pass filters and two notch filters are provided per channel and an equaliser in/out switch to bypass the effect of the equaliser and filter stages. Power to the unit is provided on the rear panel, but switched from the front. A power indicator is provided.

### Metering

The DN370 provides two LEDs per channel for the purpose of level metering. The signal LED shows incoming signal to the unit and is Pre EQ (but post gain control). The clip LED shows that the maximum output level of the unit has been achieved and the unit has entered clipping. The clip LED is sourced Post EQ (and post gain control) such that internal clipping due to excessive EQ (i.e. if a high input level is further boosted by the use of EQ) will also be shown. The clip and signal levels are shown below.

Signal (Green)	-40dBu
Clip (Red)	+22dBu

### Graphic EQ Section

The graphic EQ section of the DN370 features long throw forty-five millimetre (45mm) faders to allow fine adjustment of each frequency band. Each fader has a centre detent ('click stop') to denote the 0dB (unity gain of the band) point of the scale. The DN370 uses standard ISO third-octave standard frequency centres.

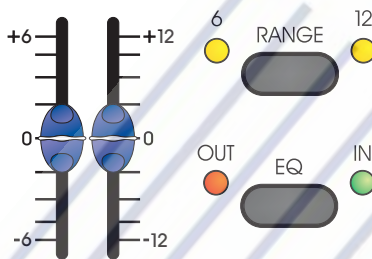

The range of the faders on each channel is switchable using that channel's RANGE switch between  $\pm 6$ dB and  $\pm 12$ dB. The current setting is indicated by the '6' and '12' LEDs above the range switch.

It may be desirable to hear the effect of the graphic equaliser settings (e.g. during sound check). This can be achieved by depressing the EQ IN/OUT switch which will bypass the EQ (and gain) settings of the DN370 allowing the user to hear the original without adjusting any fader or control. The red and green LEDs indicate whether the unit is bypassed or not.

Placing the fader of any band at the extreme upwards position will apply either 6dB or 12dB gain (depending upon the setting of the range switch) to the frequencies in that band. Placing the fader of any band at the extreme downwards position will apply either 6dB or 12dB attenuation (depending upon the setting of the range switch) to the frequencies in that band.

### Gain and Range Settings

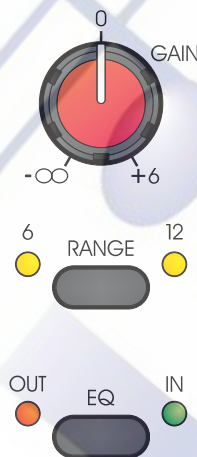

#### GAIN

The gain control provides continuous adjustment of the channel gain from -infinity (off) to +6dB with a centre detent at 0dB (unity gain). When using EQ with large amounts of cut or boost, it may be necessary to use the gain to make up or attenuate the signal. Note, however, that the gain control is bypassed when the EQ IN/OUT switch is in the OUT position but control over the channel LEDs is retained by the gain control.

#### RANGE

Although range is discussed above, a description is included here for clarity. The range of the graphic equaliser section faders on each channel is switchable using the RANGE switch between  $\pm 6$ dB and  $\pm 12$ dB. The current setting is indicated by the '6' and '12' LEDs above the range switch.

#### EQ IN/OUT

The EQ IN/OUT switch will bypass all the functions of the DN370 including the Gain control such that the output will be the same as the input. The IN/OUT switch may be used to audition settings (for example, during sound check).



**Signal Level**

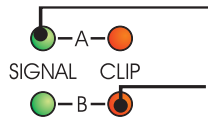

**Signal** - The signal LED shows incoming signal to the unit and is Pre EQ (but post gain control).

**Clip** - The clip LED shows that the maximum output level of the unit has been achieved and the unit has entered clipping. The clip LED is sourced Post EQ (and post gain control) such that internal clipping due to excessive EQ (i.e. if a high input level is further boosted by the use of EQ) will also be shown. The clip and signal levels are shown below.

Signal (Green)	-40dBu
Clip (Red)	+22dBu

**High Pass, Low Pass and Notch Filters**

Each channel of the DN370 includes one (1) High Pass filter, one (1) Low Pass Filter and two (2) variable frequency Notch filters. Each filter can be enabled by depressing the pot until it clicks (only a small amount of force is required). When active, the annular ring around the filter control will illuminate.

To addition the effect of the filters, either the EQ IN/OUT switch (which will also bypass the graphic equaliser) or the individual filter switch may be used.

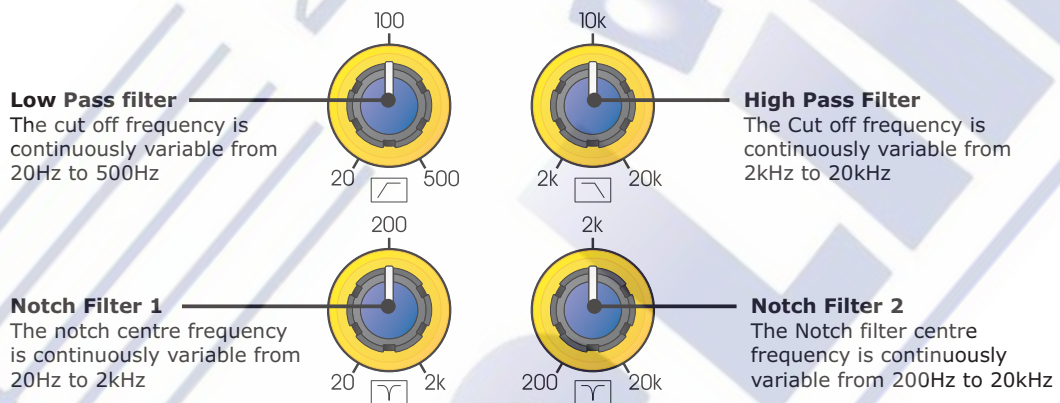



**Rear Panel Features**

The rear panel provides the audio and power connections to the DN370.

Power is provided by a single fused IEC type connector. The correct mains lead for the country to which the unit was shipped is supplied with the unit. Always replace the mains fuse with the same type and rating.

Audio connections are provided by two (2) male XLR and two (2) female XLR sockets for channel A and B inputs and outputs respectively; and also by two (2) six (6) pin Phoenix connectors. Both connectors provide balanced audio connections such that:

- Pin 1 - Ground/Screen
- Pin 2 - Hot Signal
- Pin 3 - Cold Signal

**Mains Supply**

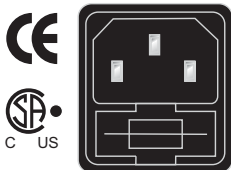

SUPPLY  
VOLTAGE  
100-240V  
AC~50-60Hz 60W  
FUSE: 5x20mm  
T0.5A L250A

Mains power is supplied to the DN370 by a single fused IEC socket on the rear of the unit. The DN370 contains an auto voltage sensing switching mode power supply that will operate where the nominal mains voltage is in the range 100 to 240 VAC.

**Audio Connection**

The audio connections to the DN370 are electronically balanced. Isolation transformers can also be fitted as factory option or retro-fit (please consult an approved Klark Teknik service agent). The input and output connectors are shown below, please read the audio connections section at the beginning of this manual for wiring diagrams and pin assignments.

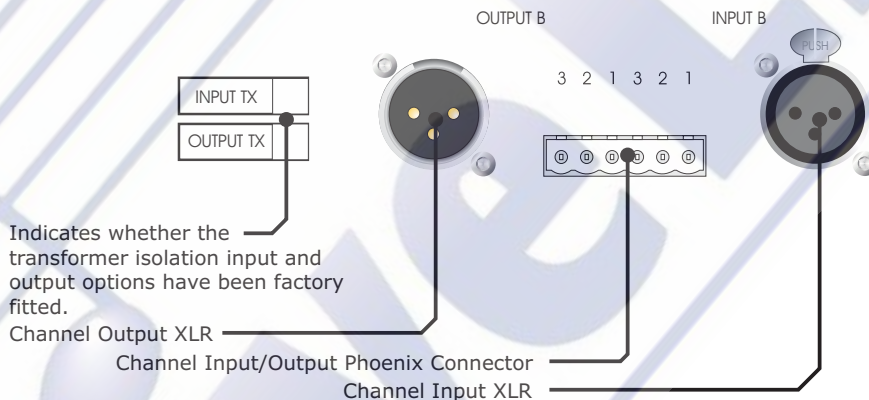



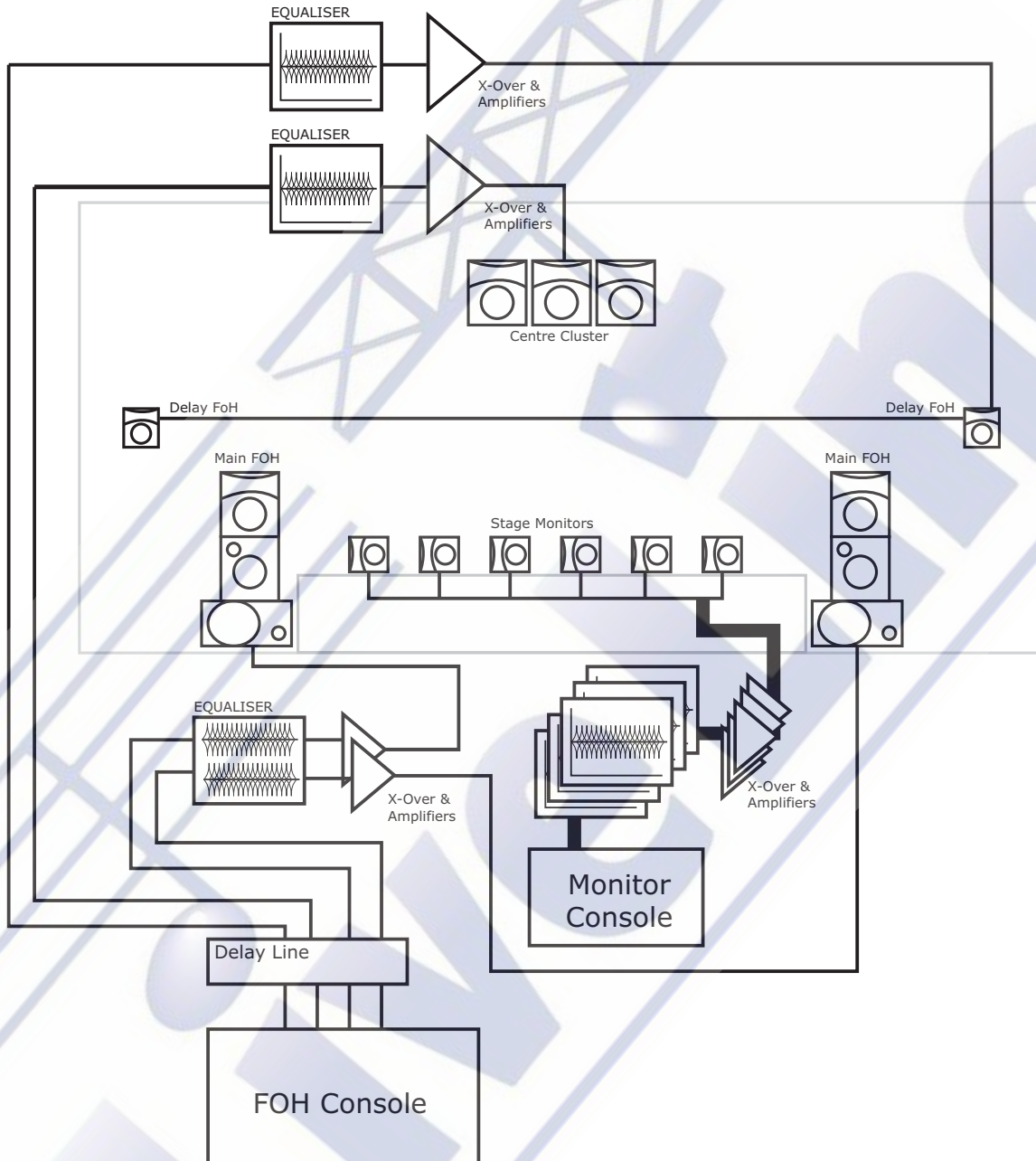



The DN370 is a thirty (30) band third octave graphic equaliser which utilises premium quality, low tolerance components to achieve a high degree of accuracy and control. Graphic equalisers may be used for corrective or creative purposes depending upon whether it is to be used live (Monitors or Front of House) or in the studio (Broadcast or Recording).

### **Studio and Creative Use**

In the control room, a graphic equaliser may be used to remove problem frequencies and improve deficiencies in room acoustics. This is commonly achieved with the use of a Real Time Analyser (RTA) such as the Klark Teknik DN60 or DN6000. The frequency centres of the DN60/6000 and the DN370 conform to ISO standards and so corrections can be made by sight directly from the RTA to the graphic.

It is important to mention, however, that graphic equalisers can only compensate so much for a room with severe acoustic problems (which may require further remedial treatment work). Graphic equalisers can only help to reduce the audible effects of standing waves and resonances and cannot overcome the loss of clarity due to rooms with long reverberation times.

The DN370 can be used to create filter effects (for example the effect of someone speaking on the telephone) using the thirty (30) equaliser bands and the high and low pass filter; in conjunction with a compressor to create a de-esser; for tonal correction of instruments or vocals and many other creative uses.

### **Live Use (Front of House)**

It is often desirable to add equalisation to a venue in order to remove any frequency deficiencies in the room before trying to engineer using the system. Again, it is common to use an RTA and measurement microphone in order to set up the equaliser using additive and subtractive equalisation to correct problems in the room. It is recommended to attenuate peaks in the room's response to the level of the surrounding frequencies rather than boost the lower bands to meet the highest. This will help to retain headroom in the equaliser and slight dips in frequency response are less noticeable than large peaks. If an overall reduction in volume is observed, the gain makeup can be used to return the output of the equaliser to the desired level.

Beware, however, that excessive equalisation (for example, using large amounts of boost at lower frequencies to compensate for poorly performing bass enclosures) will use up large amounts of system headroom which could cause the system amplifiers to clip. Causing damage to loudspeaker HF components and introducing high frequency harmonics which may sound unpleasant. Also, large amounts of low frequency boost may cause the over-excursion of bass drivers and their subsequent mechanical and electrical breakdown.

Also, many sound reinforcement systems are only capable of adequately producing frequencies up to around 18kHz. Providing high levels of boost at 20kHz to extend the frequency response of the system is likely to result in reducing the life of high frequency components in the loudspeaker while the frequency response may not be significantly improved.

There are occasions where deficiencies in room acoustics cannot be corrected by equalisation. For example, bass reduction due to phase cancellation or the cancellation around the crossover point of a loudspeaker must be corrected before the use of equalisation.

### **Live Use (Monitors)**

Monitors used on stage often need equalisation to remove any peaks in their frequency response in order to prevent feedback from on stage microphones where those frequencies exceed the maximum gain before feedback level. Further equalisation may be required in order to remove similar peaks from the characteristics of the microphones in use.

A monitor engineer may use an RTA in order to detect these peaks, but more often than not, monitor engineers have a developed sense of hearing that enables them to remove these frequencies by ear. The DN370's thirty (30) frequency bands allow a majority of feedback to be removed from the monitors, however, for feedback that is more difficult to locate or lies between bands, two variable frequency notch filters are provided which can be swept through the frequency range until the location of the feedback is located.

In addition to notch filters, a high and low pass filter are provided which can be used to remove high frequency feedback and bass rumble or over excursion of bass drivers. It may also be undesirable to have large amounts of bass in the on stage monitors. In vocal monitors, bass does not assist projection of vocals and can make the stage sound unbearable and hence, the bass element can be rolled off at the desired frequency. The fundamentals of Vocals are transmitted in a narrow audible range and will appear unaffected.





As discussed before, the benefits of equalisation are fundamentally:-

- To improve the intelligibility and natural sound of the sound system.**
- To increase the gain available in the system before feedback.**

In some circumstances, it may not be possible to achieve a natural sounding system that is completely intelligible due to poor acoustics or high levels of background noise. In these cases, a compromise must be struck by the engineer depending upon the use to which the system will be put. It may be arguable that in the case of a vocalist, intelligibility must be sought at all costs. In the case of dance music reproduction, however, it may be felt that the material should be reproduced naturally with no real concern for intelligibility of the individual lyrics.

Before starting to equalise the system, it is worth checking that it is performing correctly. Listening to the system without any equalisation may reveal underlying distortion or artefacts of the room (e.g. lengthy reverberation) that may need to be rectified before trying to equalise the room. It may also be worth using a sine tone sweep so that problems at certain frequencies that may not be immediately noticeable with pink noise can be detected and corrected before equalisation. Check, especially, the crossover points of the system which may reveal problems with the system. Note that poor coverage cannot be rectified through the use of equalisation.

The measurement microphone should ideally have a flat response or be calibrated to the analyser and placed in a sensible position where it will not be affected by nearby objects that may interfere with the local acoustics.

Using the Real Time Analyser and a pink noise source, adjust the level of the frequency bands on the graphic inversely to that shown on the RTA display so that the peaks in frequency response are reduced to the level of the other bands and similarly, the deficient bands are increased. You will need to perform the test at a reasonable level approaching normal usage volume so that the equalisation can take into account the response of the loudspeakers at normal operating level (vs. low level). It may also be desirable to take measurements at points throughout the area. It may not be possible to get perfect equalisation throughout an entire area but it may be preferable to obtain a good equalisation of the whole area rather than a perfect equalisation at a single point and poor performance at all other points. A compromise may need to be made in an effort to equalise the sound for the whole area rather than just the centre FOH position.

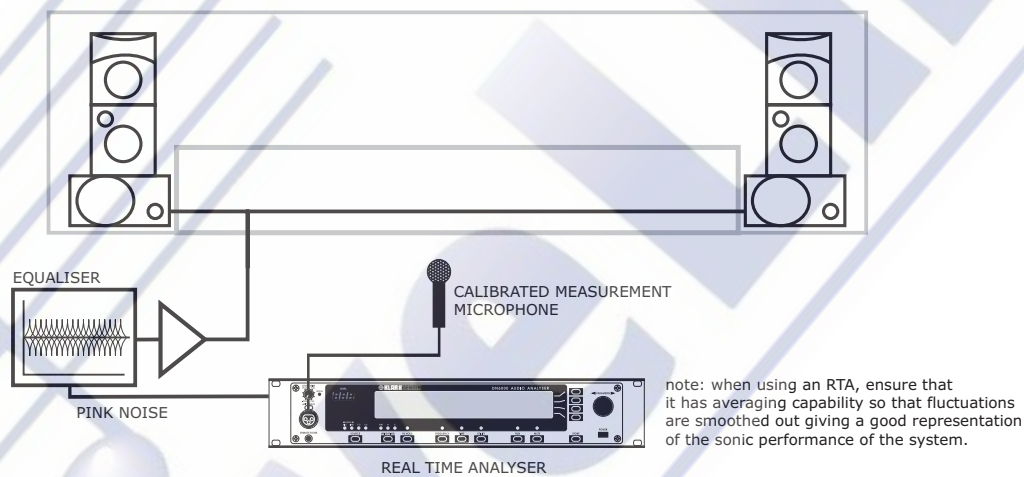

When equalising the room, bear in mind the effect upon the electronics and mechanics of the system caused by the equalisation process. If excessive equalisation is required at certain bands, consider the effect upon amplifier headroom and loudspeaker driver excursion that will result. It may not be possible to produce the response required with the limitations of the system. Excessive equalisation should act as a warning that there may be an underlying problem that may need to be rectified first (e.g. phase cancellation, blown drivers, etc...).

During the performance, the FOH or monitor engineer may want to have a microphone or solo signal feed for the RTA so that feedback may be easily detected and rectified.

**Remember**, the equaliser is not a 'cure all' device and will not solve the problems of a poor sound system, installation or venue acoustics, but when used carefully, can bring out significant improvements in the quality of reproduction of a system.



## Effects of Equalisation on Voice Reproduction

1/3 Octave Centre Frequency	Effect on voice
40, 50, 63, 80, 100, 125 160, 200, 250 315, 400, 500 630, 800, 1k	Sense of power in some outstanding bass singers  Voice fundamentals  Important for voice quality  Important for voice naturalness. Too much boost in the 315 to 1k range produced a telephone-like quality
1k25 to 4k	Vocal fricatives. Accentuation and clarity of voice  Important to speech intelligibility. Too much boost between 2kHz and 4kHz can mask certain speech sounds (e.g. 'm', 'b', 'v' can become indistinguishable). Too much boost anywhere between 1kHz and 4kHz can produce listener fatigue. Vocals can be highlighted by slightly boosting vocals at 3kHz whilst simultaneously slightly cutting instruments at that frequency.
5, 6k3, 8k 10, 12k5, 16k	Accentuation & clarity of voice  Too much boost causes sibilance ('sss').

## Effect of Equalisation on Music Reproduction

1/3 Octave Centre Frequency	Effect on Music
31, 40, 50, 63	Fundamentals of bass drum, tuba, bass and organ. These give music a sense of power but excessive use can leave the sound 'muddy'. Mains Hum (50-60Hz).
80, 100, 125	Too much boost produces 'boom'. (Fundamentals of tympani & toms) Higher harmonics of mains hum (100-120Hz)
160, 200, 250	Drum and lower bass. Too much boost produces 'boom'. 3rd Harmonics of Mains Hum.
315, 400, 500	Fundamentals of strings and percussion.
630, 800, 1k	Fundamentals and harmonics of strings, keyboards and percussion. Boosting 600-1kHz range can make instruments sound horn-like.
1k25 to 4k	Drums, guitar, accentuation of vocals, strings and brass. Excessive boost around 1-2kHz can make instruments sound 'tinny'. Excessive boost around 1-4kHz can produce 'listening fatigue'.
5k, 6k3, 8k	Accentuation of percussion, cymbals and snare drum.  Reduction at 5kHz makes overall sound more distant and transparent.  Reduction of tape hiss and system noise. 1k25 to 8k governs overall clarity and definition.
10k, 12k5, 16k	Cymbals and overall brightness. Too much boost causes sibilance.  Reduction of tape hiss and system noise.

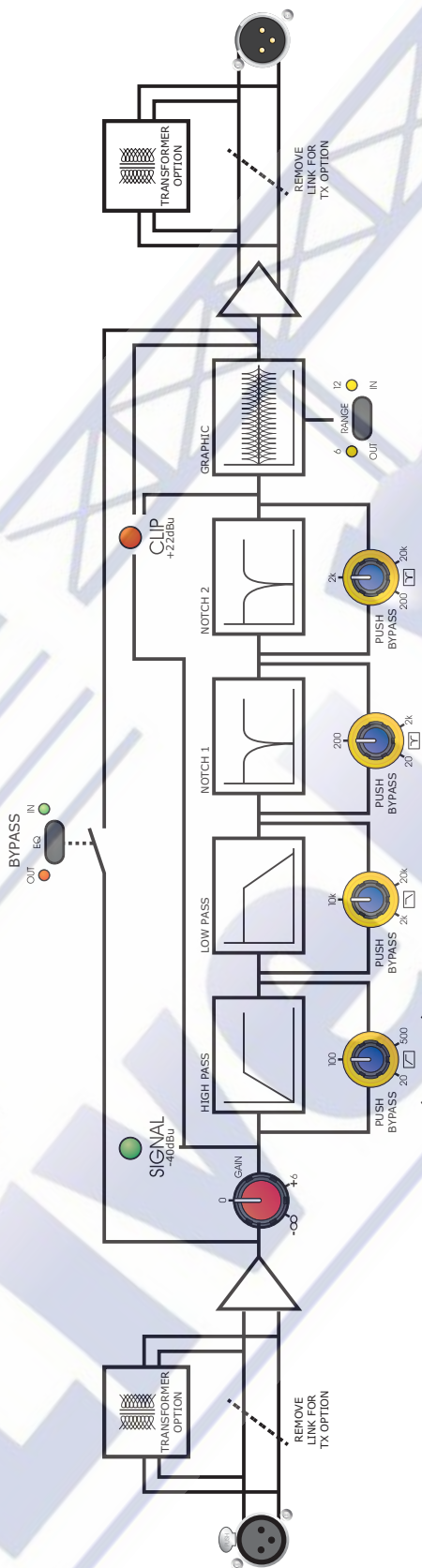

DN370 (SINGLE CHANNEL) FUNCTIONAL BLOCK DIAGRAM



The most important design decision for the DN370 was determining the equaliser response. Proportional-Q equalisation, as used on previous Klark Teknik analogue graphic equalisers, offers some key advantages over the more numerous Symmetrical-Q equalisers on the market, namely at low amounts of cut or boost the width of the filter is relatively broad and becomes narrower as the amount of boost or cut is increased, giving a more 'focused' response. This differs from a Symmetrical-Q response which boosts or cuts an increasingly wide band of frequencies, and is an important consideration in applications such as cutting particular problem frequencies, as more of the frequency spectrum is scooped out when using Symmetrical-Q equalisation; proportional-Q equalisers are much better at cutting just the problem frequency band. Symmetrical-Q equalisers are frequently, but inaccurately, termed Constant-Q as the Q is measured 3 dB up from the point of maximum attenuation when in cut, rather than the correct definition of 3dB down from the point of maximum gain (0 dB when cutting), which results in a notch filter response.

In all types of graphic equalisers, one of the key issues is how the summing of adjacent EQ bands alters the frequency response. Lower-Q filters will blend together more smoothly, but higher-Q filters provide more selective control of problems - at the expense of more frequency response ripple. A weakness of the Symmetrical-Q approach is that for small amounts of boost and cut (a very typical situation), the EQ bands have to be comparatively broad to blend smoothly to avoid excessive ripple in the frequency response, however as the Q of the EQ bands remains constant, larger amounts of boost or cut will affect an increasingly wide range of frequencies, limiting the precision and usefulness of the equaliser.

**Figure 1** and **Figure 2** show the responses of a leading Symmetrical-Q equaliser in both its 'wide' and 'narrow' modes of operation for 2dB of boost and cut, which is typical of the small adjustments made in corrective EQ applications. The 'wide' response gives a very smooth combined response for the three bands shown, however the 'narrow' response shows significant ripple in the combined response which will lead to audible artefacts such as phase distortion.

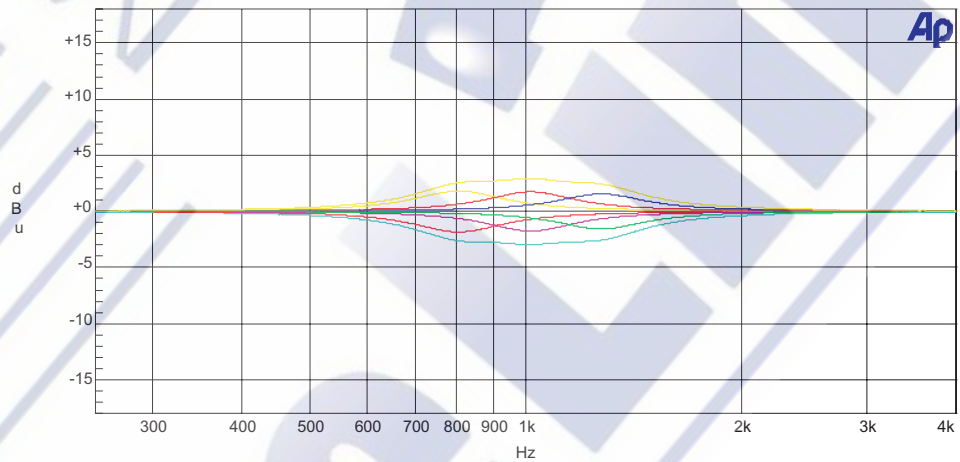

Figure 1 Symmetrical-Q equaliser "wide" mode ±2dB boost and cut

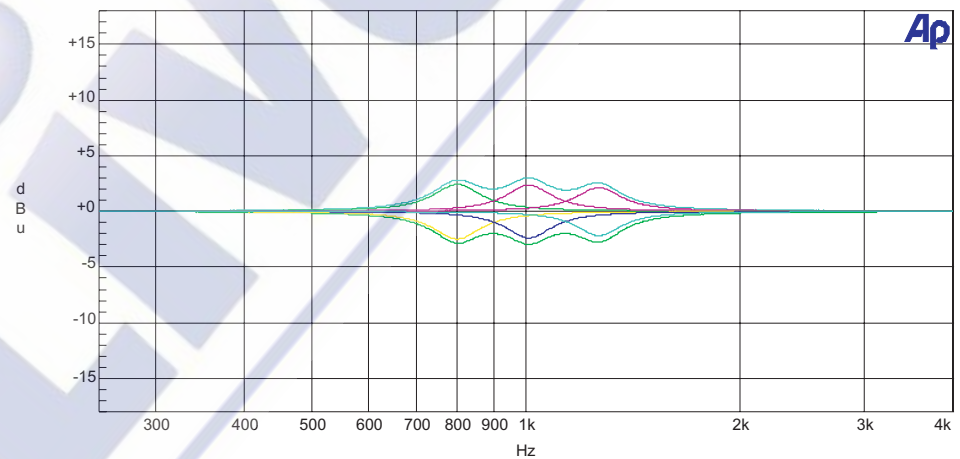

Figure 2 Symmetrical-Q equaliser "narrow" mode ±2dB boost and cut



Whilst the 'wide' response is obviously preferable for small amounts of boost and cut, **Figure 3** and **Figure 4** show the problem that occurs with using this response for full boost and cut - far more of the audio spectrum is affected by each of the bands being broader as a consequence of maintaining the same Q value.

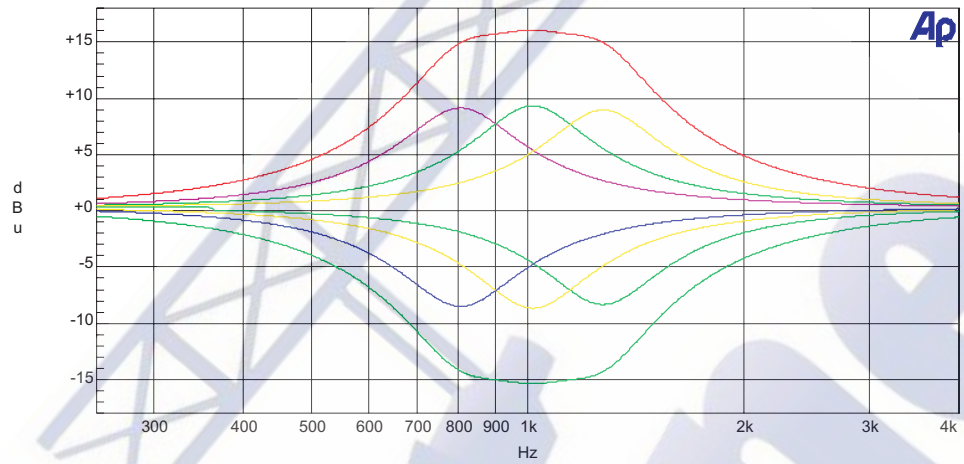

Figure 3 Symmetrical-Q equaliser "wide" mode full boost and cut

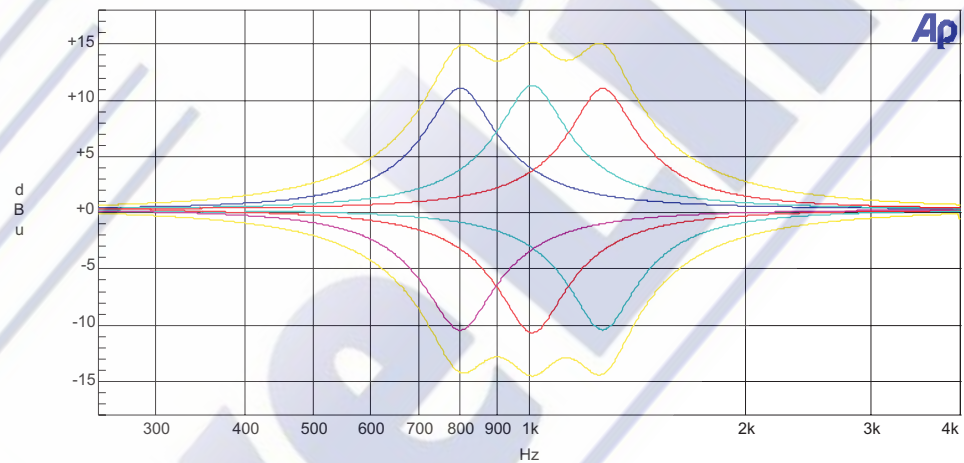

Figure 4 Symmetrical-Q equaliser "narrow" mode full boost and cut

The strength of Proportional-Q equalisation is that the EQ bands are wider at lower amounts of boost and cut, and become narrower as greater amounts are applied, giving the optimum balance of smoothness and accuracy over the entire fader travel. Extensive listening tests were carried out during the development of the DN370 to obtain the optimum response, resulting in a very musical sounding equaliser which maintains the highest level of accuracy without ever sounding harsh.



Figure 5 and Figure 6 show the DN370 response for both 2 dB and full scale boost and cut, note that the smooth combining of the bands for small amounts of boost and cut is very similar to that of the Symmetrical-Q equaliser in its 'wide' mode, whilst as more boost or cut is applied, the response becomes sharper, giving much more precise control of problem frequencies.

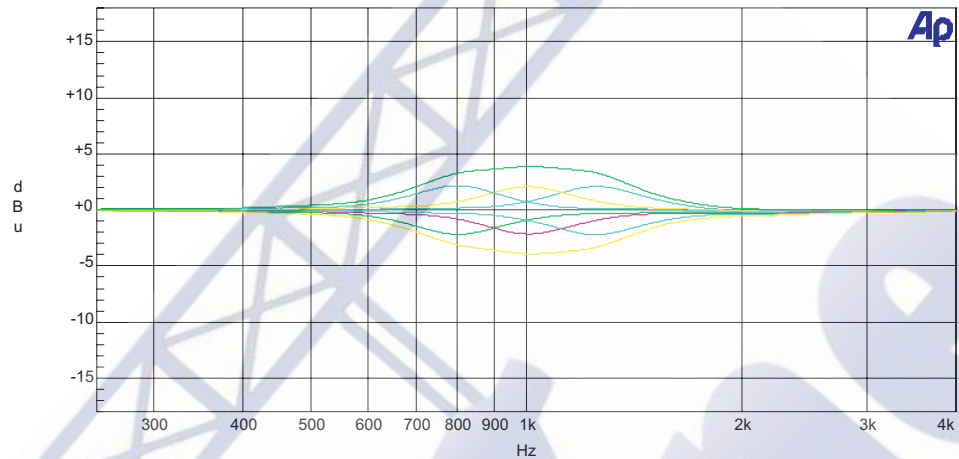

Figure 5 DN370 response ±2dB boost and cut

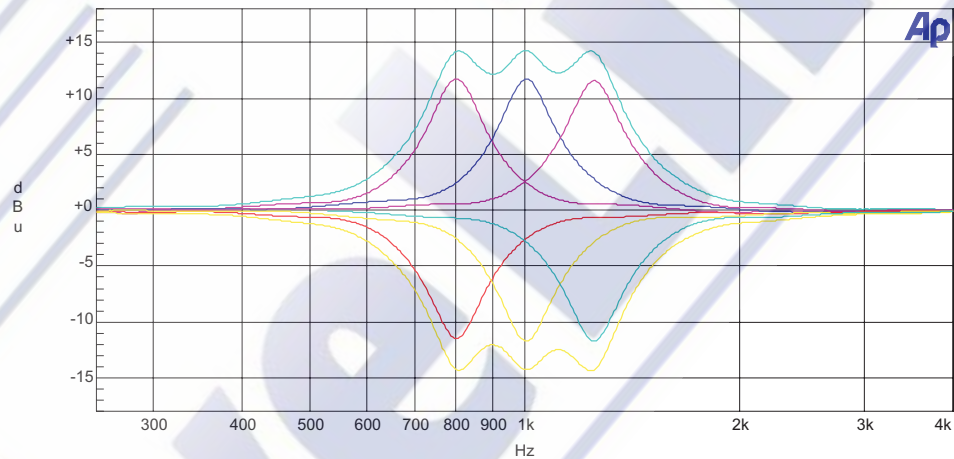

Figure 6 DN370 response full boost and cut

In addition to the graphic equaliser section, the DN370 also provides sweepable high-pass and low-pass filters and two overlapping sweepable notch filters per channel. The sweepable high- and low-pass filters can be used to enhance the intelligibility of wedge monitors by cutting out extraneous low and high frequency noise, and therefore allowing higher SPLs to be used. The two notch filters further enhance the unit's ability to precisely tune-out problem frequencies. The response of the notch filters was selected after careful listening to allow feedback to be eliminated quickly, but at the same time to be unobtrusive when in use. The high-pass, low-pass and notch filter control pots all have push-on, push-off bypass switching, with an illuminated ring around each pot to show when the filter is active. So for example, if there is particular frequency where a performer's acoustic guitar causes feedback, one of the notch filters can be used to cut that frequency, and switched out when not needed whilst still left in position for later in the set when the same instrument may be used again.



### Front-of-house

The all-new graphic EQ filters of the DN370 have been carefully selected to allow subtle tonal correction with a minimum of ripple between adjacent bands. At the same time, the proportional-Q nature of the filters ensures that in the event of acoustic feedback a tightly-focussed cut response is instantly available just by moving the fader. Range switching between  $\pm 12\text{dB}$  or  $\pm 6\text{dB}$ , together with 45mm long-throw faders provides superb control resolution and excellent visibility of control settings. The sweepable high and low-pass filters allow the frequency extremes to be matched to the capabilities of the loudspeaker system in use, leaving all the graphic EQ faders available for acoustic management of the music. Twin sweepable notch filters provide excellent suppression of room resonances with minimum impact on the program material. Positive in/out switching for all the filter sections is combined with illuminated rings around the controls for instant "at a glance" status indication.

### Monitors

The design of the all-new graphic filters with carefully selected proportional-Q responses ensures that problem frequencies can be attenuated quickly and effectively. Long-throw faders allow excellent control resolution even when using all of the available 12dB of attenuation. Interaction with adjacent bands is minimised, ensuring that more of the musical content is preserved. Even more precise are the two sweepable notch filters on each channel, which allow the surgical removal of resonances and feedback leaving everything else intact. Push switches incorporated in the control knobs allow the filters to be switched easily in and out (for example when an artist is using different instruments during a show). Illuminated rings around the control knobs ensure that the filter status is always visible at a glance. High and low pass filters allow the frequency limits to be accurately controlled for each output. Whilst very useful for conventional wedge monitors, this feature really comes into its own when combining in-ear and wedge monitors, allowing the response of each monitor subsystem to be tailored to the artist's requirements.



### Examples

The additional versatility offered by the DN370's unique feature set of filters allows unparalleled precise control of frequency response. The examples adjacent show how the filters can be used on their own and in conjunction with the graphic equaliser to handle problems encountered in real world corrective EQ applications.

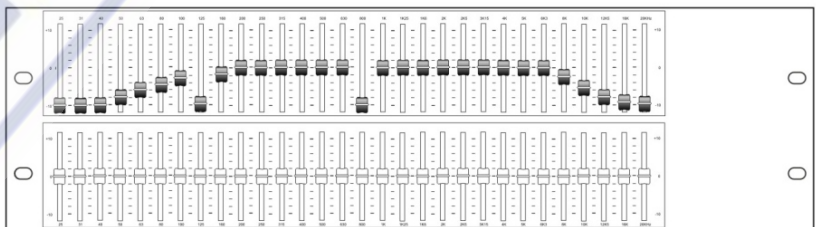
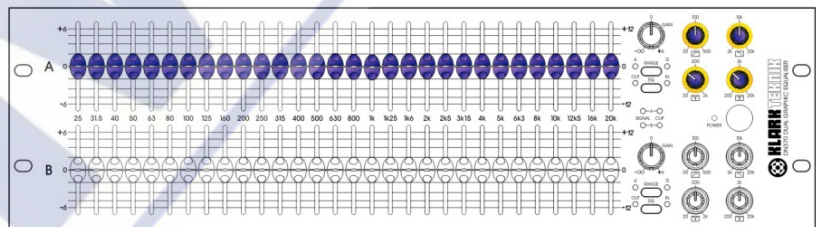
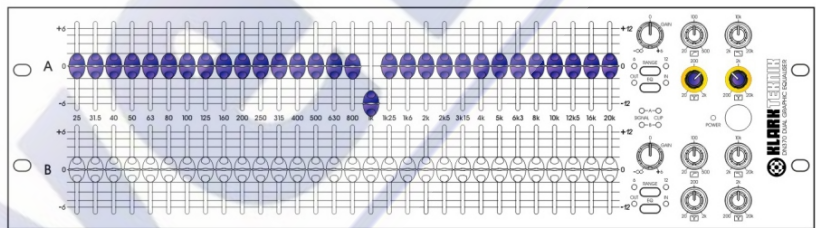
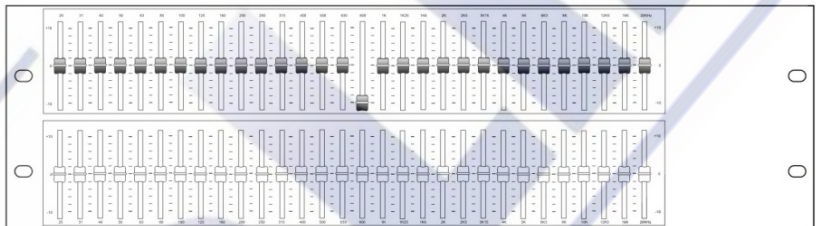
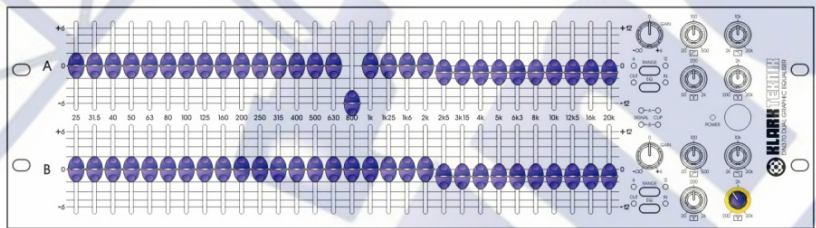
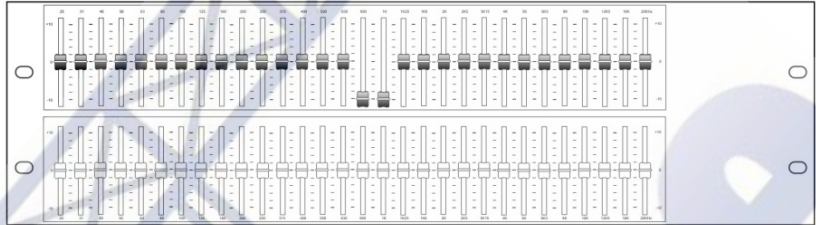
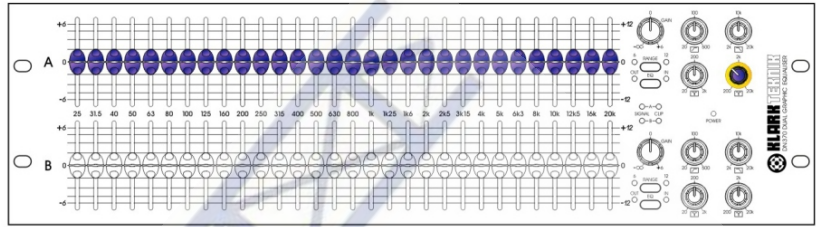





The notch filters on the DN370 can be used to eliminate a common problem with graphic equalisers - the control of frequencies that lie between the ISO standard frequency centres. In the adjacent example to cut 900 Hz, a single notch filter can be used to produce a steep notch in the frequency response without affecting adjacent frequencies (a). In contrast with a Symmetrical-Q equaliser, the only solution available is to cut both the 800 Hz and 1 kHz faders, and whilst there is nearly 16 dB of attenuation at 900 Hz, a very broad range of frequencies are also affected, particularly when a Symmetrical-Q equaliser with a wide response is used (c). A narrow Symmetrical-Q response affects a less broad range of frequencies, although at the expense of less attenuation at the desired frequency (b).

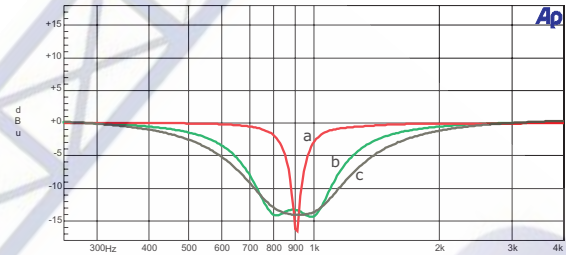

The proportional-Q response of the DN370 simultaneously allows gentle contouring of the frequency spectrum and precise control of specific problem frequencies. The sweepable notch filters further enhance this capability. The blue trace shows a high shelf filter created using the faders from 2.5 kHz upwards, and a notch created by fully cutting the 800 Hz fader (Channel A on the front panel view). The red trace shows the same shelf filter, but using a notch filter to cut 800 Hz, showing the greater precision offered by the notch filters (Channel B on the front panel view).

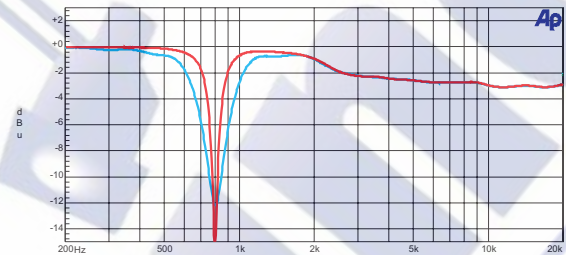

In contrast, the limitation of Symmetrical-Q equalisers can be seen in the adjacent traces - a wide response (a) gives a smooth shelf filter but affects a very broad range of frequencies when attempting to use it as a notch filter, whilst a narrow response (b) gives a much sharper notch, but at the expense of excessive ripple in the shelf filter. Even with a narrow response, the Symmetrical-Q equaliser affects a broader range of frequencies than using the Proportional-Q response of the DN370's faders.

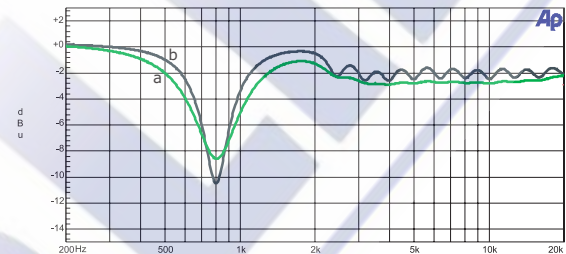

The ability to overlap the notch filters, both with each other and with the graphic EQ bands, allows very deep notches to be created. The adjacent trace shows the responses of a single notch filter, two overlapped notch filters (a) and two notch filters overlapped with an EQ band (b), each resulting in greater attenuation (c). Nearly 45 dB of attenuation is possible when using the notch filters in conjunction with the EQ bands.

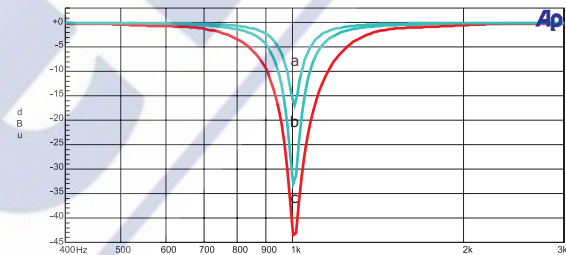

A typical application of DN370 would be to EQ a monitor wedge, the red trace shows how both the high and low pass filters have been used to shape the overall response, and the use of the two notch filters to attenuate particular problem frequencies. Note that the faders are completely flat, and so can be used to make incremental changes relative to the response shown above. In contrast, a Symmetrical-Q equaliser even with a high pass filter cannot produce the same response, either with a wide or narrow response (b and a traces). The effect of the interaction caused by combining the individual fader responses makes it impossible to match the response created using the DN370's filters, and whilst the narrow response is more able to produce the desired notches, it is again at the expense of ripple in the low pass filter response.

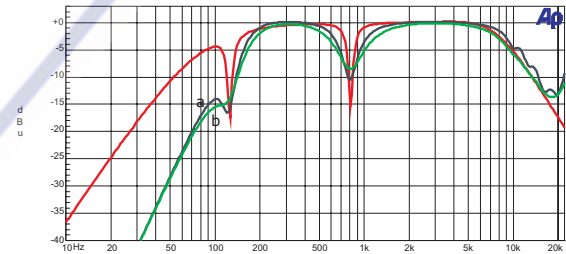

A Symmetrical-Q equaliser lacking the additional filters cannot produce a high pass filter response using just its faders, either with a wide or narrow response (b and a traces). The user may assume that subsonic frequencies are being attenuated by cutting the bottom faders but the graph shows that this is not the case.

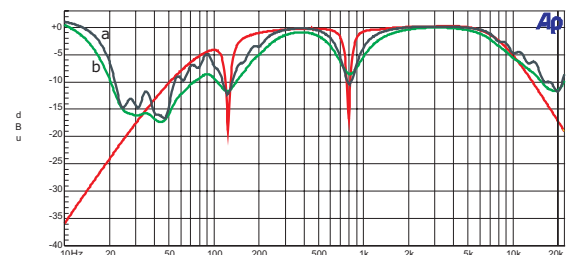





<b>Inputs</b>	<b>Two</b> Type Impedance (Ohm) Max input level	Electronically balanced (pin 2 hot) 20k +22dBu
<b>Outputs</b>	<b>Two</b> Type Minimum load impedance Source impedance Maximum output level	Electronically balanced (pin 2 hot) 600ohms <60ohms +22dBu >2k ohm
<b>Performance</b>	Frequency response EQ out EQ in (flat) Distortion (THD+N) Dynamic range Overload indicator Gain	 ±0.5dBu, 20Hz-20kHz relative to signal at 1kHz ±0.5dBu < 0.003% @ 1kHz, +4dBu >114dB (20Hz-20kHz unweighted), ±12dB range +20dBu - infinity to +6dBu
<b>Equalisation</b>	<b>30 Bands</b> Centre Frequencies Tolerance Maximum Boost/Cut High Pass Filter Slope Low Pass Filter Slope Notch filter	To BS EN ISO 266:1997 25Hz-20kHz, 1/3 octave ±5% ±12dB, ±6dB 12 dB/octave 12 dB/octave Attenuation >18dB, Q=32
<b>Terminations</b>	Audio Power	3-pin XLR and 6-pin Phoenix 3-pin IEC
<b>Power Requirements</b>	Voltage Consumption	100V-240V a.c. <60W
<b>Dimensions</b>	Height Width Depth	133mm (5.25 inch) 3U High 482mm (19 inch) 205mm (8 inch)
<b>Weight</b>	Nett Shipping	5.8kg 7.0kg
<b>Options</b>		Input and output balancing transformer

BS EN ISO 266:1997 Frequency Centres:

The ISO standard frequencies

25 Hz, 31.5 Hz, 40 Hz, 50 Hz, 63 Hz, 80 Hz, 100 Hz, 125 Hz, 160 Hz, 200Hz, 250 Hz, 315 Hz, 400 Hz, 500 Hz, 630 Hz, 800 Hz, 1.00 kHz, 1.25 kHz, 1.60 kHz, 2.00 kHz, 2.50 kHz, 3.15 kHz, 4.00 kHz, 5.00 kHz, 6.30 kHz, 8.00 kHz, 10.0 kHz, 12.5 kHz

Due to a policy of continual improvement, the Klark Teknik Group reserves the right to alter the function or specification at any time without notice.

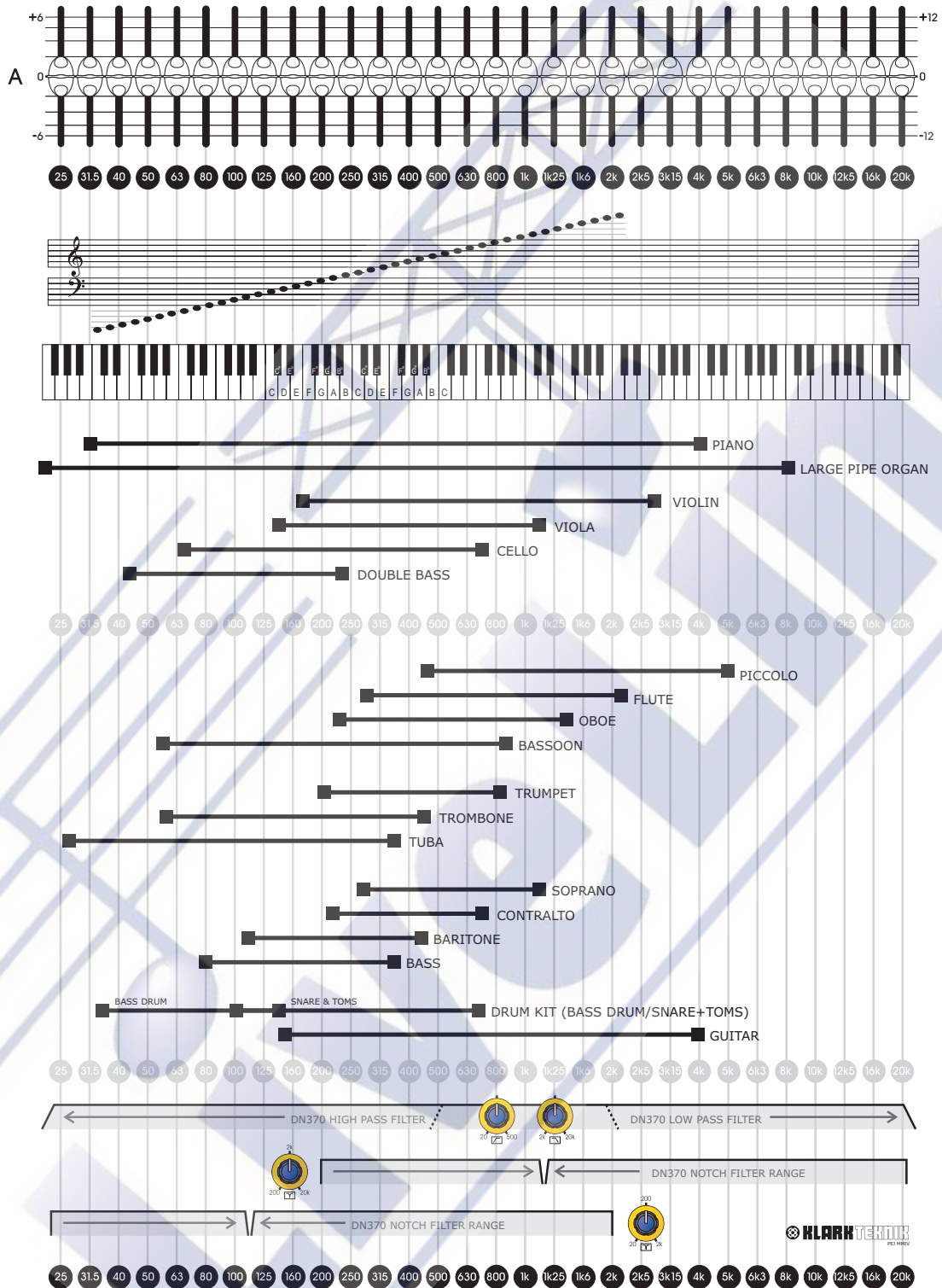

Note: The above information is provided as a rough guide to the range of fundamental frequencies used by various common instruments. In addition to these, various amounts of higher harmonic content will also be produced.  
 A=440Hz

**KLARK TERMINOR**  
DN370 DUAL GRAPHIC EQUALISER

Channel A: +6, 0, -6, +12, -12

Channel B: +6, 0, -6, +12, -12

Frequency sliders: 25, 31.5, 40, 50, 63, 80, 100, 125, 160, 200, 250, 315, 400, 500, 630, 800, 1k, 1k25, 1k6, 2k, 2k5, 3k15, 4k, 5k, 6k3, 8k, 10k, 12k5, 16k, 20k

Controls: RANGE, EQ, GAIN, POWER

**KLARK TERMINOR**  
DN370 DUAL GRAPHIC EQUALISER

Location \_\_\_\_\_

Application \_\_\_\_\_

Date \_\_\_\_\_

**KLARK TERMINOR**  
DN370 DUAL GRAPHIC EQUALISER

Channel A: +6, 0, -6, +12, -12

Channel B: +6, 0, -6, +12, -12

Frequency sliders: 25, 31.5, 40, 50, 63, 80, 100, 125, 160, 200, 250, 315, 400, 500, 630, 800, 1k, 1k25, 1k6, 2k, 2k5, 3k15, 4k, 5k, 6k3, 8k, 10k, 12k5, 16k, 20k

Controls: RANGE, EQ, GAIN, POWER

**KLARK TERMINOR**  
DN370 DUAL GRAPHIC EQUALISER

Location \_\_\_\_\_

Application \_\_\_\_\_

Date \_\_\_\_\_



Klark Teknik DN370 Operators Manual  
Issue 1 - February 2004  
DOC02-DN370  
(c) Klark Teknik Group (UK) PLC.

In line with the company's policy of continual improvement, specifications and function may be subject to change without notice. The contents of this Operators Manual was correct at the time of writing. E&OE.