



---

INSTRUCTION BOOK FOR  
Fast-Fold® Deluxe  
Screen Frames  
Standard Leg

---

# Procedure

Da-Lite Fast-Fold® Deluxe frames are made of 1-1/4" square hard aluminum tubing with an anodized finish. With proper care they will provide many years of use. Please follow the set up instructions below (steps 1-6).

1. Remove the frame from its case and wrapping. Position it as shown (front view).

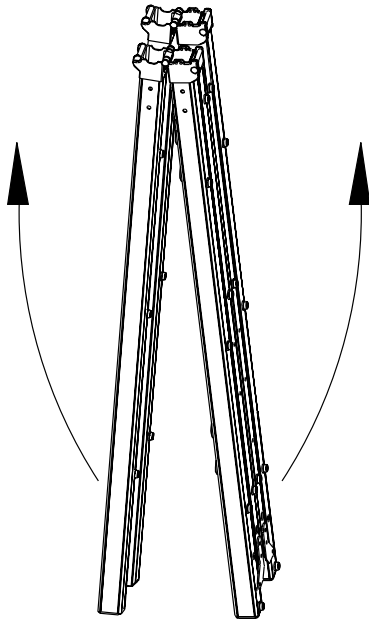

**Two Section Frame**

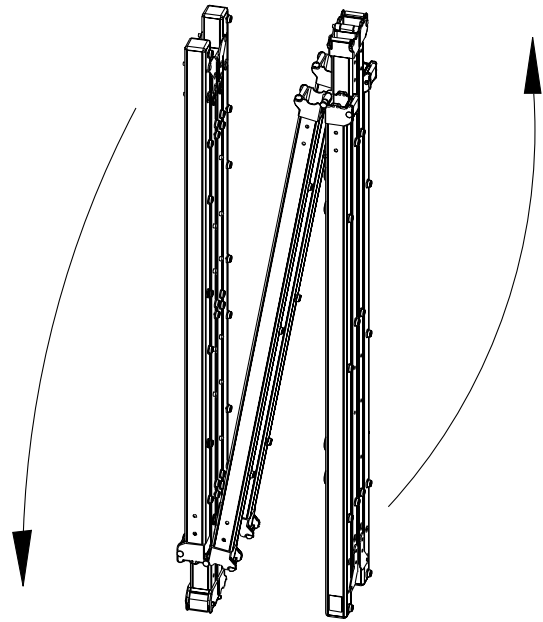

**Three Section Frame**

2. Unfold the frame following the directions given below so that it is lying flat, snap latches will automatically lock.

Looking From The Top

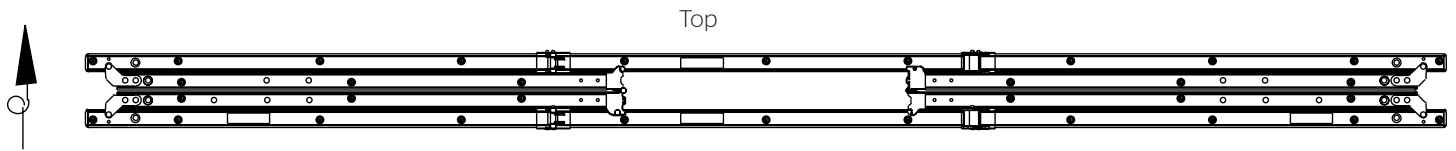

Rotate 90°

## Procedure

3. While holding the bottom of the frame in place, lift the top of the frame to unfold the sides. Lock down all four corner braces.
4. Lay the frame on the floor.
5. Match top of screen surface (labeled TOP) with top of frame.
6. Snap all four corners.
7. Starting at the bottom section, snap the center button. Continue snapping the remaining buttons.
8. Snap the top and sides in the same manner.
9. Attach Leg to each side of frame using at least 2 Speedy Cranks per leg. **NOTE:** Speedy Crank at bottom of leg should be on side of leg away from screen. Do not tighten Speedy Cranks until all are started.

Screens under 10' in height will include 6 Speedy Cranks (3 per leg).

Screens 10' in height and over will include 8 Speedy Cranks (4 per leg).

Any screen ordered with optional HD Legs will include 10 Speedy Cranks (5 per leg).

10. Height Adjustment. Fast-Fold® Deluxe screen height is adjustable in 6" increments either up or down. Normal screen height is 44" from bottom of frame to floor and is the standard height for use with presentation drapery accessories.

**NOTE:** Do not extend frame so that more than half of the frame height is above the top of the legs.

11. To fold frame, unlock all four corner braces. Push the blue snap latch buttons and fold the frame.

**NOTE:** for some frames fold the top and bottom first.

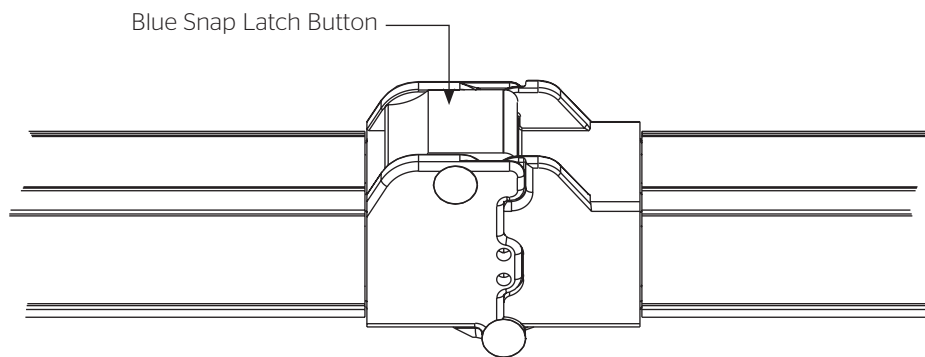
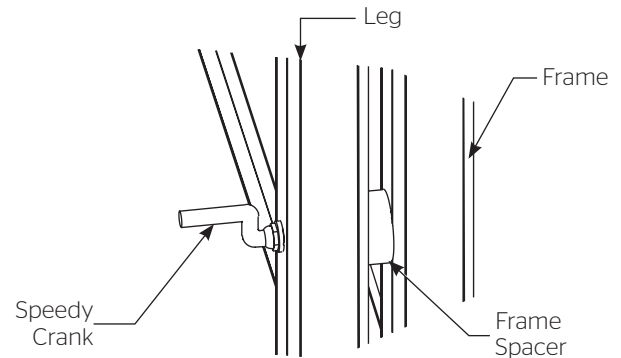
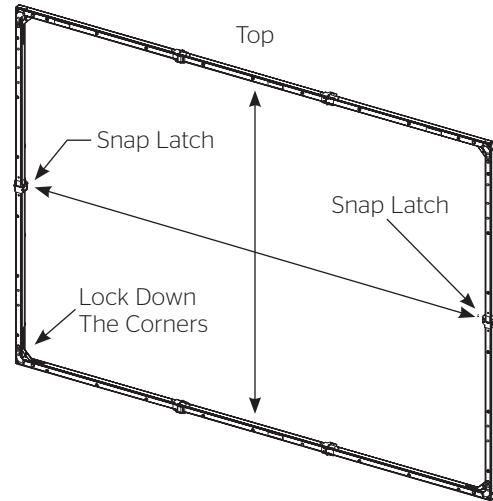

## Folding The Picture Surface For Packing

---

When folding the screen material for packing, observe the following precautions before proceeding:

1. The surface should not be allowed to contact painted, varnished or plastic finished objects for a prolonged period of time.
2. Make certain the picture surface is on a clean, flat surface.

Then proceed in the following manner:

Place clean white tissue paper - with no printing - on top of the picture surface. If tissue is not available, a soft **white** cloth or something similar will serve the same purpose. Under no conditions should newspaper or anything similar be used since these may damage the screen material.

1. With the viewing side facing up, fold the fabric in half from top to bottom. Make certain when folding, the surface does not come in contact with either the black binding, grommets or snap buttons.
2. If the material on the first fold is more than 3 feet high, then fold once again, but always place clean tissue paper between the folds.
3. For large size screens, fold in half again if necessary. Make certain when folding, the surface does not come in contact with either the black binding, grommets or snap buttons.

4. After the top to bottom folding procedure is completed, then fold from left to right and continue folding until the fabric is of sufficient size to fit into the leatherette case.

**NOTE:** Keep the screen surface in the envelope provided when it is not in use. Failure to observe these normal precautions may cause discoloration of the material.

### Cleaning

**Da-Mat<sup>®</sup>, Da-Tex<sup>®</sup>, High Contrast Da-Tex<sup>®</sup>, Pearlescent, Cinema Vision, Dual Vision, Ultra Wide Angle and 3D Virtual Black™** surfaces can be cleaned as follows:

Using a white clean cloth (100% cotton preferred) that is dampened with clear water, gently wipe the area in one direction. Do not use a circular motion. Using a dry 100% cotton cloth, wipe dry after each cleaning session. To clean a stubborn stain or a sticky surface, use denatured alcohol (methanol or methyl alcohol) following the same procedure as for water. For extremely stubborn stains, use V M & P, Naphtha or Super Naphtha and follow the same procedure as for water.

**NOTE:** Fast-Fold<sup>®</sup> screens are shipped with tissue paper packed between the folds. This keeps the material from sticking to itself and makes it easier to unfold.

## Theatre-Like Set Created With Fast-Fold® Presentation Drapery Accessories

---

For a finished, professional appearance, Fast-Fold® screens can be dramatically enhanced with the Drapery Presentation Accessory Kit. Handsome velour drapes in a choice of three eye-catching colors surround the screen on four sides, providing an attractive stage front to the audience.

The Presentation Drapery Accessory Kit serves a second function when used with a rear projection surface. It shields extraneous light from the projector as well as hiding projection and other equipment from the audience.

An optional Adjustable Skirt Bar provides a versatile method of changing the picture ratio.

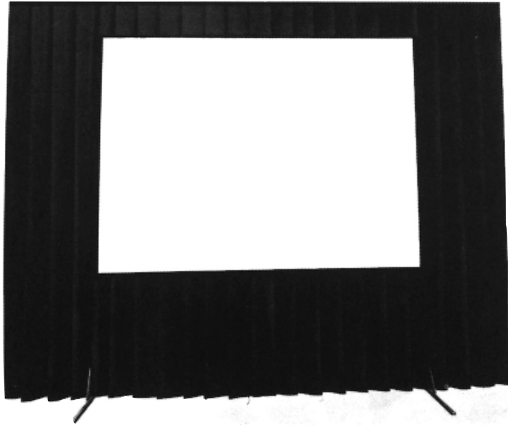

The hardware in the kit is made of lightweight aluminum and, along with the folded velour drapes, is packed into a convenient easy to carry poly case. The entire kit can be set up in minutes. Case optional at additional cost.

### **Presentation Drapery Accessory Kit (Illustrated)**

Consists of a set of velour drapes in choice of Blue, Gray or Black, Valance, two Wings, Skirt, Valance Bar, and two Wing Bars.

- All bars attach to screen frame with slip on clamps. No tools needed.
- Valance Bar attaches to frame first. Wing Bars then attach to Valance Bar.
- Valance Bar extends 12" above frame. Wing Bars extend 32" on each side.
- Wing Bars attach to frame when ceiling height prevents use of Valance.
- 45" High Skirt snaps to bottom of screen or to optional Adjustable Skirt Bar.





## LIMITED ONE YEAR WARRANTY ON DA-LITE PRESENTATION PRODUCTS

Milestone AV Technologies LLC warrants certain Da-Lite branded products to the original purchaser only, to be free from defects in materials and workmanship for a period of one (1) year from the date of purchase by the original purchaser; provided they are properly operated according to Da-Lite's instructions and are not damaged due to improper handling or treatment after shipment from the factory.

This warranty does not apply to equipment showing evidence of misuse, abuse or accidental damage, or which has been tampered with or repaired by a person other than authorized Da-Lite personnel.

Da-Lite's sole obligation under this warranty shall be to repair or to replace (at Da-Lite's option) the defective part of the merchandise. Returns for service should be made to your Da-Lite dealer. If it is necessary for the dealer to return the screen or part to Da-Lite, transportation expenses to and from Da-Lite are payable by the purchaser and Da-Lite is not responsible for damage in shipment. To protect yourself against damage or loss in transit, insure the product and prepay all transportation expenses.

**TO THE MAXIMUM EXTENT PERMITTED BY APPLICABLE LAW, THIS WARRANTY IS IN LIEU OF ALL OTHER WARRANTIES, EXPRESS OR IMPLIED, INCLUDING WARRANTIES AS TO FITNESS FOR USE AND MERCHANTABILITY.** Any implied warranties of fitness for use, or merchantability, that may be mandated by statute or rule of law are limited to the one (1) year warranty period. This warranty gives you specific legal rights, and you may also have other rights, which vary from state-to-state. **TO THE MAXIMUM EXTENT PERMITTED BY APPLICABLE LAW, NO LIABILITY IS ASSUMED FOR EXPENSES OR DAMAGES RESULTING FROM INTERRUPTION IN OPERATION OF EQUIPMENT, OR FOR INCIDENTAL, DIRECT, OR CONSEQUENTIAL DAMAGES OF ANY NATURE.**

In the event that there is a defect in materials or workmanship of a Da-Lite product, you may contact our Sales Partners at PO Box 137, Warsaw, IN 46581-0137, (574) 267-8101, (800) 622-3737.

**IMPORTANT: THIS WARRANTY SHALL NOT BE VALID AND DA-LITE BRANDED PRODUCTS SHALL NOT BE BOUND BY THIS WARRANTY IF THE PRODUCT IS NOT OPERATED IN ACCORDANCE WITH THE DA-LITE WRITTEN INSTRUCTIONS.**

Keep your sales receipt to prove the date of purchase and your original ownership.



A Milestone AV Technologies Brand

3100 North Detroit Street  
Warsaw, Indiana 46582  
P: 574.267.8101 or 800.622.3737  
F: 574.267.7804 or 877.325.4832  
E: [info@da-lite.com](mailto:info@da-lite.com)  
[www.da-lite.com](http://www.da-lite.com)

DL-0284 01.14

© 2013 Milestone AV Technologies LLC. Printed in U.S.A.

89123