



Xtreme X-900

ORDERCODE D4171



SHOWELECTRONICS FOR PROFESSIONALS

Congratulations!

You have bought a great, innovative product from DAP Audio.

The DAP Audio Xtreme series bring excitement to any venue. Whether you want simple plug-&-play action or a sophisticated show, this product provides the effect you need.

You can rely on DAP Audio, for more excellent audio products.

We design and manufacture professional audio equipment for the entertainment industry.

New products are being launched regularly. We work hard to keep you, our customer, satisfied.

You can get some of the best quality, best priced products on the market from DAP Audio.

So next time, turn to DAP Audio for more great audio equipment.

Always get the best -- with DAP Audio !

Thank you!



DAP Audio

DAP Audio Xtreme X-700, X-900, X-1300, X-2000, X-2400 Product Guide

Warning	2
Safety-instructions.....	2
Operating Determinations.....	3
Description	4
Features.....	4
Overview Front side.....	4
Overview Back side.....	5
Installation	6
Set Up and Operation	6
OFF LINE Mode.....	6
ON LINE Mode.....	7
PC SOFTWARE Operation.....	8
- 1. Menu Command.....	8
- 2. Parameter Adjustment.....	9
Connection Cables	10
Maintenance	11
Troubleshooting	11
Product Specifications	12

WARNING

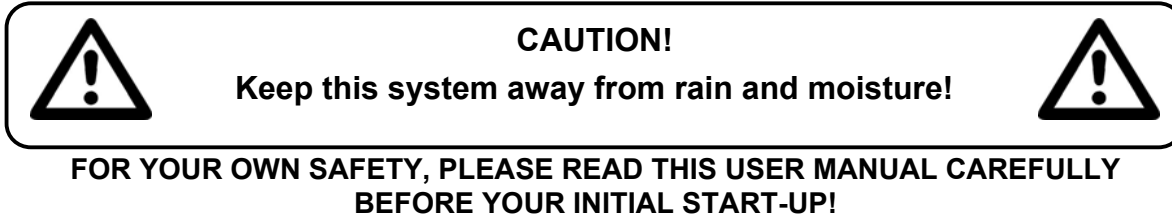

SAFETY INSTRUCTIONS

Every person involved with the installation, operation and maintenance of this system have to:

- be qualified
- follow the instructions of this manual

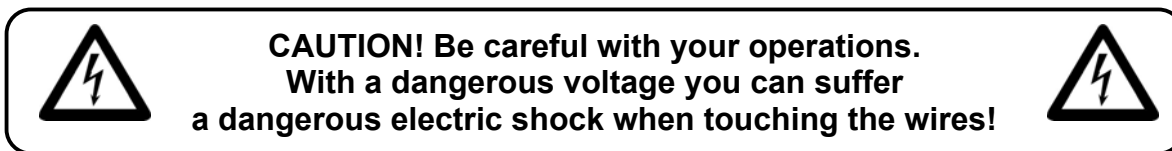

Before you initial start-up, please make sure that there is no damage caused by transportation. Should there be any, consult your dealer and do not use the system.

To maintain perfect condition and to ensure a safe operation, it is absolutely necessary for the user to follow the safety instructions and warning notes written in this manual.

Please consider that damages caused by manual modifications to the system are not subject to warranty.

This system contains no user-serviceable parts. Refer servicing to qualified technicians only.

IMPORTANT:

The manufacturer will not accept liability for any resulting damages caused by the non-observance of this manual or any unauthorized modification to the system.

- Never let the power-cord come into contact with other cables! Handle the power-cord and all connections with the mains with particular caution!
- Never remove warning or informative labels from the unit.
- Never use anything to cover the ground contact.
- Do not insert objects into air vents.
- Do not connect this system to a dimmerpack.
- Do not switch the system on and off in short intervals, as this would reduce the system's life.
- Do not open the device and do not modify the device.
- Do not open this device. Risk: hazardous radiation exposure.
- Only use system indoor, avoid contact with water or other liquids.
- Avoid flames and do not put close to flammable liquids or gases.
- Always disconnect power from the mains, when system is not used. Only handle the power-cord by the plug. Never pull out the plug by tugging the power-cord.
- Make sure you don't use the wrong kind of cables or defective cables.
- Make sure that the signals into the mixer are balanced, otherwise hum could be created.
- Make sure you use DI boxes to balance unbalanced signals; All incoming signals should be clear.
- Make sure that the available voltage is not higher than stated on the rear panel.

- Make sure that the power-cord is never crimped or damaged. Check the system and the power-cord from time to time.
- Make sure that the amplifier is turned down, before turning the power on or off. So you can avoid supersonic frequencies, which could damage your speakers.
- Don't put your equipment next to TV, radio, etc., because of interference or distortion.
- If you connect other parts of the system, be careful of ground loops.
- The best way to avoid ground loops is connecting the electrical system ground to one central point ("star" system). In this case the mixer can act as a central point.
- To prevent humming, please try different combinations of ground-lift or connect all chassis to the system ground, either by a power cable or frontcover rack screws.
- Before changing the ground, always turn off your amplifier.
- Please read this manual carefully and keep it for future reference. Remember that the amplifier has a better value on the market, if you save the carton and all packing materials.
- Always operate the unit with the AC ground wire connected to the electrical system ground.
- Connecting amplifier outputs to oscilloscopes or other test equipment, while the amplifier is in bridged mode, may damage both the amplifier and test equipment.
- Do not drive the inputs with a signal level bigger, than required to drive the equipment to full output.
- In system setup, the amplifier's output power must be 50%-100% more than the loaded loudspeakers rated power.
- Please turn off the power switch, when changing the power cord or signal cable, or select the input mode switch.
- In typical use, Please set the volume to 0dB position.
- Sometimes, when you want to send one signal to more than one amplifier, you should use a signal distributor.
- If your Dap Audio device fails to work properly, discontinue use immediately. Pack the unit securely (preferably in the original packing material), and return it to your Dap Audio dealer for service.
- Allow time to cool down, before cleaning or servicing.
- For replacement use fuses of same type and rating only.
- Prevent distortion! Make sure that all components connected to the Xtreme have sufficient power ratings. Otherwise distortion will be generated because the components are operated at their limits.
- Avoid ground loops! Always be sure to connect the power amps and the mixing console to the same electrical circuit to ensure the same phase!
- If system is dropped or struck, disconnect mains power supply immediately. Have a qualified engineer inspect for safety before operating.
- If the system has been exposed to drastic temperature fluctuation (e.g. after transportation), do not switch it on immediately. The arising condensation water might damage your system. Leave the system switched off until it has reached room temperature.
- This device falls under protection class I. Therefore it is essential to connect the yellow/green conductor to earth.
- Repairs, servicing and electric connection must be carried out by a qualified technician.
- WARRANTY: Till one year after date of purchase.

OPERATING DETERMINATIONS

If this system is operated in any other way, than the one described in this manual, the product may suffer damages and the warranty becomes void.

Any other operation may lead to dangers like short-circuit, burns, electric shock, etc.

You endanger your own safety and the safety of others!

Improper installation can cause serious damage to people and property !

Description of the device

Features

The Xtreme X-700, X-900, X-1300, X-2000, X-2400 are professional high-end amplifiers :

- Integrated system
- Perfect electronic protections: short circuit/overload protection, overheating Protection and direct current excursion protection.
- Network control
- Power supply
 - X-700:** RMS 2 X 750W(4Ω), RMS 2 X 430W(8Ω)
 - X-900:** RMS 2 X 870W(4Ω), RMS 2 X 520W(8Ω)
 - X-1300:** RMS 2 X 1050W(4Ω), RMS 2 X 720W(8Ω)
 - X-2000:** RMS 2 X 1520W(4Ω), RMS 2 X 1020W(8Ω)
 - X-2400:** RMS 2 X 1760W(4Ω), RMS 2 X 1250W(8Ω)
- Built-in 48-bit DSP processor and dynamic range up to 116 dB, 48kHz sampling rate A/D, D/A
- Low noise and lower distortion
- Well-designed signal generator: sin wave and white noise
- S/PDIF input/output (option)
- Matrix control, up to 255 units controlled by selecting address code
- Save and recall all parameters via PC parallel port
- 5 band PEQ, limiter threshold, attack time and release time adjusted, delay (max 8ms), phase invert, input gain control
- Two crossover: range, 20Hz-20kHz. Crossover frequency adjusted. Slope: -6, -12, -18 and -24dB butterworth
- Three output modes: stereo, mono and bridge
- THD+N: 0,08%@ 1 kHz
- Frequency response: 20Hz-20kHz
- 2 x 20 LCD display with backlit

Overview



Fig. 1

1. CH A: Adjust the volume of channel A / Set up amplifier ID device nr1-255 / Noise Gate ON/OFF
2. CH B: Adjust the volume of channel B / Load Program 1-11 / Auto Mute ON/OFF
3. Input interface to PC
4. Output interface to PC
5. 2 x 20 LCD Display with backlit
6. Power ON/OFF

Backside

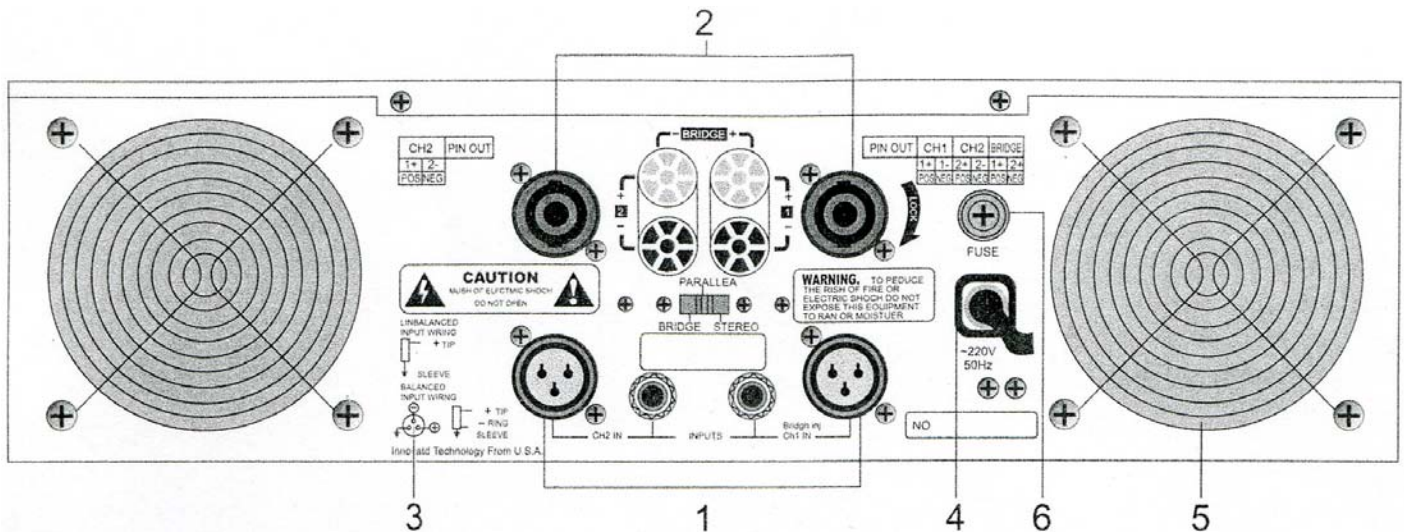

Fig. 2

1. Balanced input (0 dB / 30 KOhm): CH A and CH B have one pair of balanced inputs with a cannon connector.
2. Power output: output should be connected to the loudspeaker. The CH A/CH B outputs of a DSP series amplifier have one waterproof jack and one group of binding post.
Note: The rated power and the impedance load of the loudspeaker or loudspeaker system must match the amplifier (see technical specification), Only use a speaker cable (normally provided with one red and one black wire). Do not use the signal cable (normally used for microphone and audio equipment).
3. Earthed ON/FLOATING: Separate the signal earth from the chassis.
Use this selector to stop earth loops, which can occur when several units are connected.
4. Power: AC 200-240V+ 1 0% 50-60HZ.
5. Air vents
Don't obstruct or insert objects into air vents.

Installation

Remove all packing materials from the Xtreme. Check that all foam and plastic padding is removed. Screw the equipment into a 19" rack. Connect all cables.

Always disconnect from electric mains power supply before cleaning or servicing.
Damages caused by non-observance are not subject to warranty.

Set Up and Operation

Before plugging the unit in, always make sure that the power supply matches the product specification voltage. Do not attempt to operate a 120V specification product on 240V power, or vice versa. Install this device on a flat surface, not bending or curved. Do not supply power before all components of the system are set up and connected properly.

There are 3 different modes: Offline Mode, Online Mode, PC Software Operation

OFF LINE MODE

Switch on the power, the system accesses the OFFLINE mode.

A. Adjust the volume: turn CHA/CHB button to adjust the input level of CHA/CHB.

B. Setup the amplifier ID:

Press CHA button for about 3 seconds, the LCD shows:

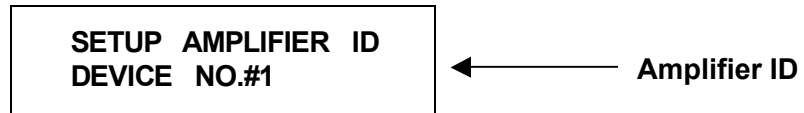

Then, turn CH A to change the amplifier ID from 1 to 255. Press CH A button again and save the setting.

C. Load program

Press the CH B button for about 3 seconds, the LCD shows:

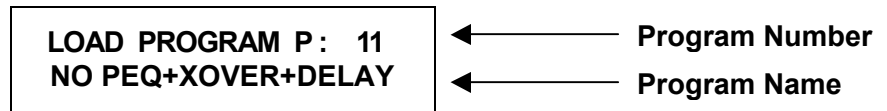

Then, turn CH A to select one program [1 -11]. Press CH B button again, save the setting and load the selected program. At the same time, the LCD shows: LOADING..... Several seconds later, LOADING is finished and the system returns to the menu

D. SETUP VOLUME PROTECT: Under menu LOAD PROGRAM, press the CH B button again for about 3 seconds and then the LCD shows:



Turn the CH B button to switch on/off AUTO MUTE. Then, press the CHB button again to save the setting. AUTO MUTE: ON. When the power is on, the volume of CH A/CH B is automatically MUTE. AUTO MUTE: OFF. When the power is on, the volume of CH A/CH B returns to the setting, when the power was off the last time.

Note:

1. Program No. 11 is not used in the online mode without PEQ, XOVER and DELAY. The other 10 programs can be saved and recalled in the online mode.
2. The volume is automatically muted after every LOAD PROGRAM.
3. When the system switches from the online mode to the offline, the system can load the program that is saved in the online mode. At the same time, the volume is muted automatically.

ONLINE MODE

1. Connect the amplifier to the PC with the right cable. Insert one end of the cable into the parallel port of the PC and the other end into the PC REMOTE port in the front panel of amplifier.
Start DSP testing software.
2. CONNECTION
Click the Debug button and then click Connect. Select a device number (1-255). If this number is the same as the amplifier ID, the LCD shows:

**CONNECT SUCCESSFUL
PC CONTROL DEVICE**

At that time, the system can be tested by the DSP software. All the functions from the offline mode are not valid.

3. DISCONNECT

Click Debug button and then click Disconnect, the LCD shows:

**CONNECT CANCEL
MCU CONTROL DEVICE**

Then the software testing is not valid. The system returns to the offline mode.
Regarding the operation of DSP software, please refer to the online help of it.



Fig. 3

PC SOFTWARE OPERATION

1. MENU COMMAND

File menu

Open	Open an existing File of the PC
Save	Save the current setting to the PC
Read From Memory	Read the parameters of the program
Send To Memory	Save the value of the parameters to the program
Exit	Exit PC application

Mode menu

Stereo	Stereo mode, the input and output of the left and right channel is independent
Bridge	Bridge mode, the output phase of the left and right channel is reversed
Mono	Mono mode, the output phase of the left and right channel is the same

Test menu

Sine wave	Sine wave Test, generate the sin wave signal for testing the system. Frequency range: 20Hz~20kHz
Noise	White noise Test, generate the white noise signal for testing the system.

Debug menu

Connect	Connect the device to the PC and then controlled by the PC
Disconnect	Disconnect the device from the PC

Help menu

Content	index to topics
About DSP	Version and the information of company

2. PARAMETER ADJUSTMENT

In the main interface click the relative button to adjust the Gain, PEQ, Xover, Delay , Phase and Limiter Gain.

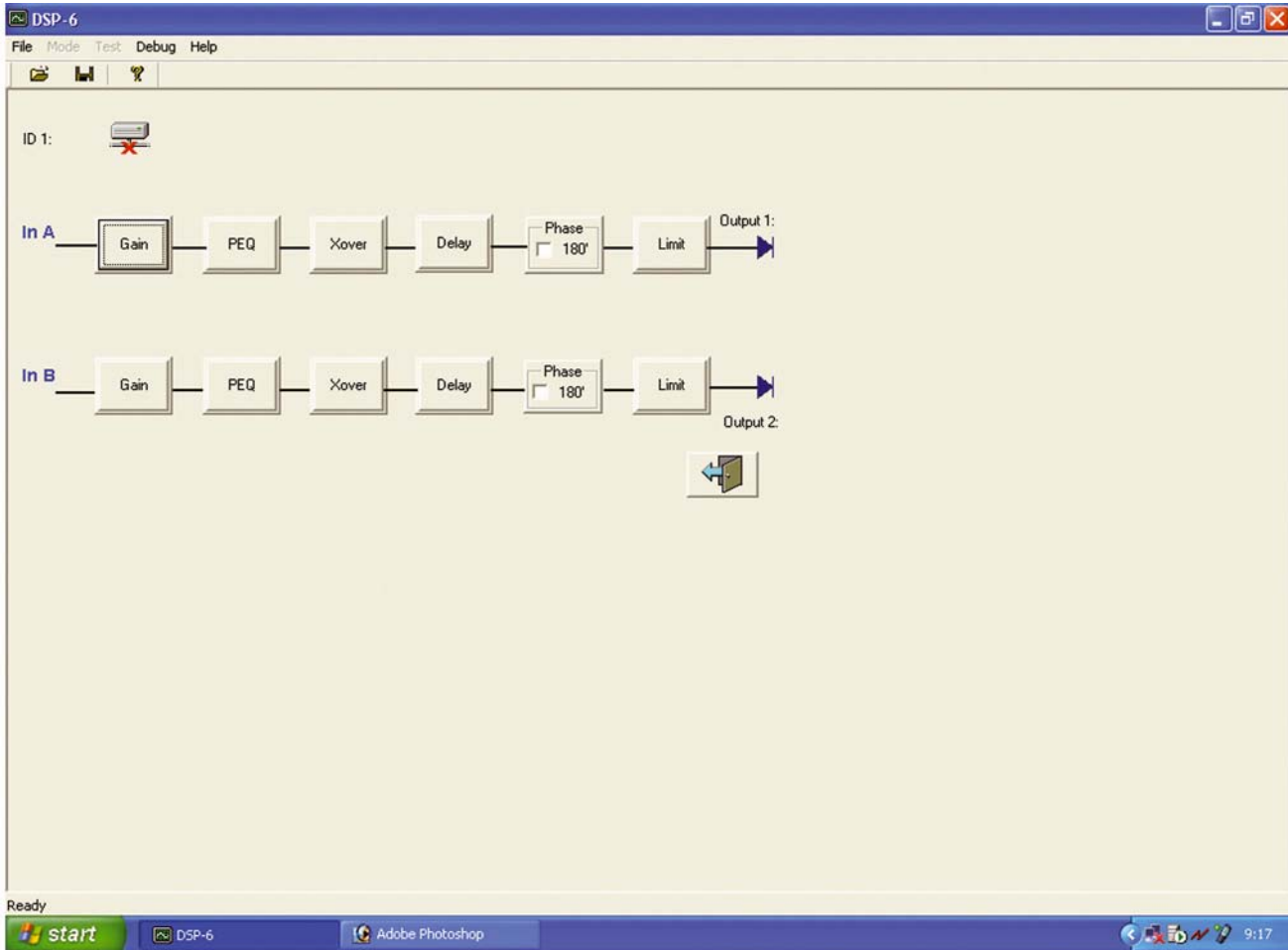

Fig. 4

- 1) Gain
Click Gain button to set the level of the Left / Right Channel. Volume Range:-60dB to 6dB.
- 2) PEQ
Click "PEQ" button and then the frequency, gain, Q value and flat (on/off) of 5 band PEQ can be set.
Frequency range: 19.7Hz~20.2kHz
Q value: 0.4-128
- 3) Xover
Click the Xover Button and then the parameters of the filter (slope and frequency of HPF/LPF) can be set.
The minimum Frequency of LPF is not lower than the maximum frequency of HPF.
- 4) Delay
Click the Delay button and then the delay unit and the delay time can be set. Max delay: 8ms
- 5) Phase
Click the 180° check box to select the reverse phase 0°, 180°
- 6) Limiter
Click the limiter button and then the threshold, hold time, attack time and release time can be adjusted.
This is used for protecting the system.

Connection Cables

Take care of the connector cables, always holding them by the connectors and avoiding knots and twists when coiling them: This gives the advantage of increasing their life and reliability, which is always to your advantage.

Periodically check that your cables are in good condition, that they are correctly wired and that all their contacts are perfectly efficient: a great number of problems (faulty contacts, ground hum, discharges, etc.) are caused entirely by using unsuitable or faulty cables.

Headphones

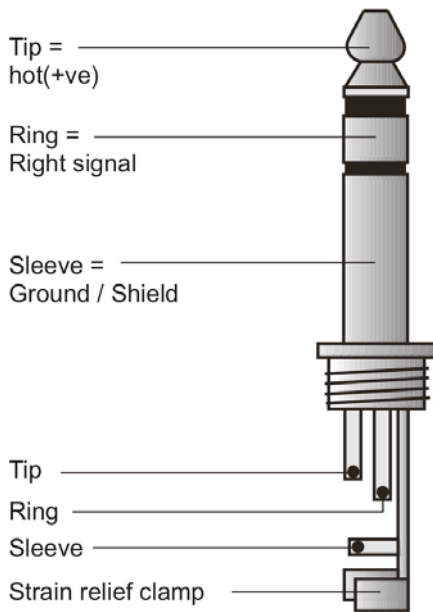

Unbalanced mono 1/4" jack plug

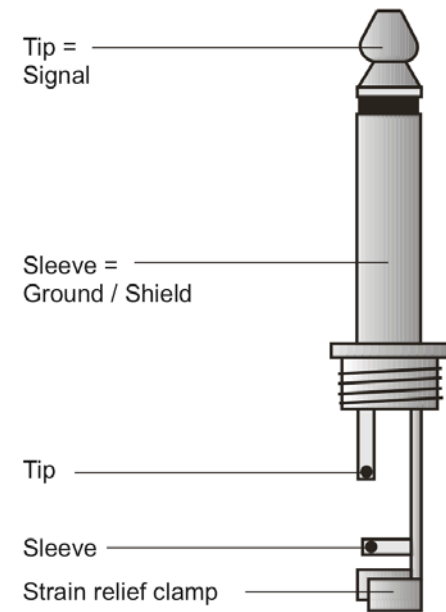

Balanced mono 1/4" jack plug

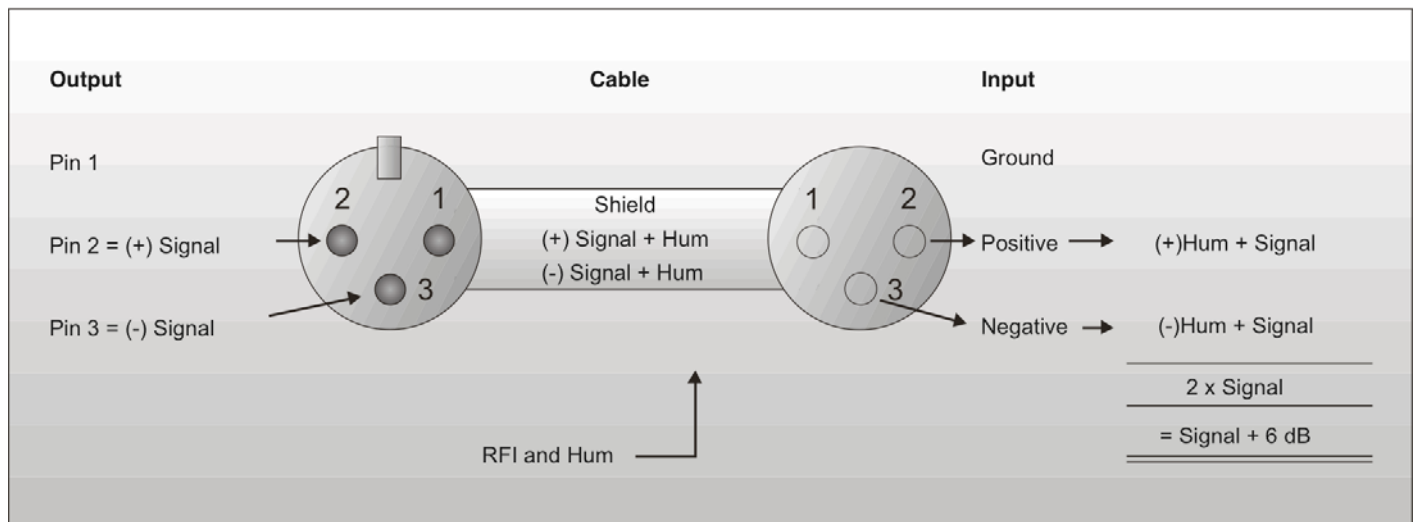
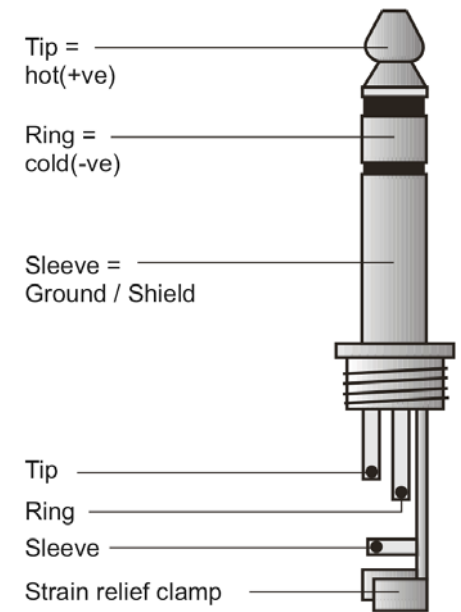

Compensation of interference with balanced connections

Balanced use with XLR connectors

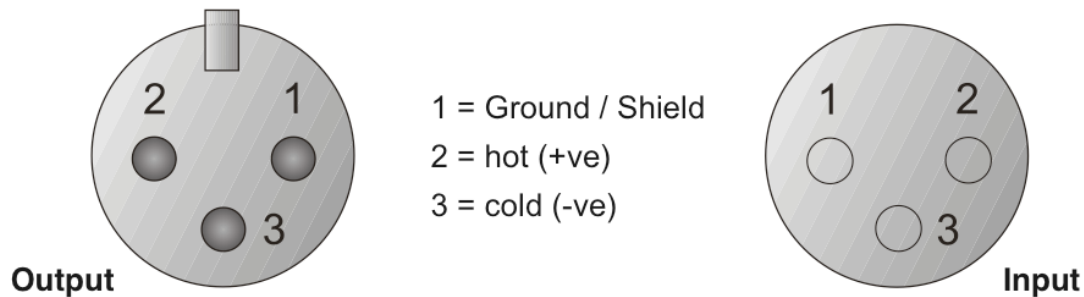

For unbalanced use PIN 1 and PIN 3 have to be bridged

Maintenance

The DAP Audio Xtreme X-900 requires almost no maintenance. However, you should keep the unit clean. Disconnect the mains power supply, and then wipe the cover with a damp cloth. Do not immerse in liquid. Do not use alcohol or solvents. Keep connections clean. Disconnect electric power, and then wipe the DMX and audio connections with a damp cloth. Make sure connections are thoroughly dry before linking equipment or supplying electric power.

Replacing a Fuse

Power surges, short-circuit or inappropriate electrical power supply may cause a fuse to burn out. If the fuse burns out, the product will not function whatsoever. If this happens, follow the directions below to do so.

1. Unplug the unit from electric power source.
2. Insert a screwdriver into the slot in the fuse cover. Turn the screwdriver to the left, at the same time gently push a bit (Turn and Push). The fuse will come out.
3. Remove the broken fuse. If brown or unclear, it is burned out.
4. Insert the replacement fuse into the holder where the old fuse was. Reinsert the fuse cover.
Be sure to use a fuse of the same type and specification. See the product specification label for details.

Troubleshooting

DAP Audio Xtreme X-900

This troubleshooting guide is meant to help solve simple problems. If a problem occurs, carry out the steps below in sequence until a solution is found. Once the unit operates properly, do not carry out following steps.

1. If the device does not operate properly, unplug the device.
2. Check the fuse, power from the wall, all cables, etc.
3. If all of the above appears to be O.K., plug the unit in again.
4. If you are unable to determine the cause of the problem, do not open the amplifier, as this may damage the unit and the warranty will become void.
5. Return the amplifier to your Dap Audio dealer.

Product Specifications

Specification	X-700	X-900	X-1300	X-2000	X-2400
8 Ω Stereo Power (RMS)	430W x 2	520W x 2	720W x 2	1020W x 2	1250W x 2
4 Ω Stereo Power (RMS)	750W x 2	870W x 2	1050W x 2	1520W x 2	1760W x 2
8 Ω Bridge Power (RMS)	150W x 2	1800W x 2	2200W x 2	2800W x 2	3240W x 2
Frequency Response	20 Hz -20KHz: + 0.1 / - 3 dB (1W / 8 Ω)				
THD into 4 Ω , 1 KHz	<0.05% @750W	<0.05% @870W	<0.05% @1050W	<0.05% @1520W	<0.05% @1760W
SMPER IMD	<0.01% @120W into(60Hz & 7 KHz)	<0.01% @180W into(60Hz & 7 KHz)	<0.01% @230W into(60Hz & 7 KHz)	<0.01% @330W into(60Hz & 7 KHz)	<0.01% @550W into(60Hz & 7 KHz)
Slew Rate	40V/ μ s	40V/ μ s	40V/ μ s	40V/ μ s	50V/ μ s
Damping Factor	300:1,1 KHz@8 Ω	300:1,1 KHz@8 Ω	300:1,1 KHz@8 Ω	300:1,1 KHz@8 Ω	350:1,1 KHz@8 Ω
Input CMRR (@1KHz)	>60dB	>60dB	>60dB	>60dB	>60dB
Voltage Gain	50x standard	50x standard	50x standard	61x standard	80x standard
Input Sensitivity (@8 Ω)	0.775V for rated power	0.775V for rated power	0.775V for rated power	0.775V for rated power	0.775V for rated power
Input Impedance	20K Ω , balanced 10K Ω , unbalanced	20K Ω , balanced 10K Ω , unbalanced	20K Ω , balanced 10K Ω , unbalanced	20K Ω , balanced 10K Ω , unbalanced	20K Ω , balanced 10K Ω , unbalanced
Hum and Noise	-103dB	-103dB	-103dB	-103dB	-103dB
Crosstalk	<60dB	<60dB	<60dB	<60dB	<60dB
Connectors (per channel)	Female XLR (pin 2+), TRS (tip +), 5 – way Output binding post				
Power Supply	230 V / 50 – 60 Hz				
Max. Current Draw 220V	10 A	12 A	12 A	16 A	20 A
Cooling	2 variable speed DC fans				
Controls	2 front attenuators, rear panel signal ground lift jumper				
Indicators (per channel)	PROTECT LED, CLIP LED, SIGNAL LED, POWER LED				
Protection	Temperature, DC, sub / ultea, sonic short circuit, IGM, output				
Dimensions (LxWxH)	483x400x 89 mm	483x400x 89 mm	483x400x 89 mm	483x400x 89 mm	483x400x 89 mm
Gross Weight	30 Kg	32 Kg	34 Kg	36 Kg	38 Kg
Net Weight	38 Kg	30 Kg	32 Kg	34 Kg	36 Kg

Design and product specifications are subject to change without prior notice.

